**User's
Manual**



**MX100
Data Acquisition Unit**

Foreword

Thank you for purchasing the MX100 Data Acquisition Unit. This user's manual describes the functions, installation and wiring methods, operating procedures, handling precautions, and other information about the MX100 Data Acquisition Unit (hereinafter the "MX100"). To ensure correct use, please read this manual thoroughly before beginning operation. The five manuals below relating to the MX100 are provided in addition to this one. Read them along with this manual. This manual (IM MX100-01E), the MX100 Data Acquisition Unit Operation Guide (IM MX100-02E), and the MX100 Standard Software User's Manual (IM MX180-01E) are all available on the MX100 Manual CD-ROM.

Manual Title	Manual No.	Description
MX100 Data Acquisition Unit Operation Guide	IM MX100-02E	Describes concisely the handling of the MX100 and the basic operations of the MX100 Standard Software.
Precautions on the Use of the MX100/MW100 Data Acquisition Unit	IM MX100-71E	Summarizes the usage precautions of the MX100/MW100.
MX100/MW100 Data Acquisition Unit Installation and Connection Guide	IM MX100-72E	Describes concisely the installation and wiring procedures of the MX100/MW100.
Control of pollution caused by MX100/MW100 products	IM MX100-91C	Describes control of pollution caused by the product.
MX100 Standard Software User's Manual	IM MX180-01E	Describes the functions and operations of the MX100 Standard Software that comes standard with the MX100 main module.

Notes

- When configuring an MX100 system, the versions of the instruments used in the system indicated by the hardware style number and software release number must meet the following conditions.
 - The main module style number must be greater than or equal to the style numbers of any input/output modules.
 - The PC software release number must be greater than or equal to the style number of the main module.
Certain functions may become disabled on instruments or software that do not meet these conditions, or the system may not be able to be built.
- This manual describes MX100 style number "S3." Check the style number on the name plate.
- The contents of this manual are subject to change without prior notice as a result of continuing improvements to the instrument's performance and functions.
- Every effort has been made in the preparation of this manual to ensure the accuracy of its contents. However, should you have any questions or find any errors, please contact your nearest YOKOGAWA representative, dealer, or sales office.
- Copying or reproducing all or any part of the contents of this manual without the permission of Yokogawa Electric Corporation is strictly prohibited.
- The TCP/IP software of this product and the document concerning the TCP/IP software have been developed/created by YOKOGAWA based on the BSD Networking Software, Release 1 that has been licensed from the University of California at Berkeley.

Trademarks

- DAQMASTER is a registered trademark of Yokogawa Electric Corporation.
- Microsoft and Windows are registered trademarks or trademarks of Microsoft Corporation in the United States and/or other countries.
- Adobe and Acrobat are registered trademarks or trademarks of Adobe Systems Incorporated.
- Company and product names that appear in this manual are registered trademarks or trademarks of their respective holders.
- The company and product names used in this manual are not accompanied by the registered trademark or trademark symbols (® and ™).

Revisions

1st Edition: May, 2003 2nd Edition: November, 2004 3rd Edition: June, 2006
4th Edition: February, 2008

Safety Precautions

About This Manual

- Please pass this manual to the end user.
- Read this manual thoroughly and have a clear understanding of the product before operation.
- This manual explains the functions of the product. It does not guarantee that the product will suit a particular purpose of the user.
- Under absolutely no circumstances may the contents of this manual be transcribed or copied, in part or in whole, without permission.
- The contents of this manual are subject to change without prior notice.
- Every effort has been made in the preparation of this manual to ensure the accuracy of its contents. However, should you have any questions or find any errors or omissions, please contact your nearest YOKOGAWA dealer.

Precautions Related to the Protection, Safety, and Alteration of the Product

- The following safety symbols are used on the product and in this manual.



Danger. Refer to the user's manual. This symbol appears on dangerous locations on the instrument which require special instructions for proper handling or use. The same symbol appears in the corresponding place in the manual to identify those instructions.)



Functional ground terminal (do not use this terminal as a protective ground terminal.)



Protective grounding terminal



Alternating current

- For the protection and safe use of the product and the system controlled by it, be sure to follow the instructions and precautions on safety that are stated in this manual whenever you handle the product. Take special note that if you handle the product in a manner that violates these instructions, the protection functionality of the product may be damaged or impaired. In such cases, YOKOGAWA does not guarantee the quality, performance, function, and safety of product.
- When installing protection and/or safety circuits such as lightning protection devices and equipment for the product and control system or designing or installing separate protection and/or safety circuits for fool-proof design and fail-safe design of the processes and lines that use the product and the control system, the user should implement these using additional devices and equipment.
- If you are replacing parts or consumable items of the product, make sure to use parts specified by YOKOGAWA.
- This product is not designed or manufactured to be used in critical applications that directly affect or threaten human lives. Such applications include nuclear power equipment, devices using radioactivity, railway facilities, aviation equipment, air navigation facilities, aviation facilities, and medical equipment. If so used, it is the user's responsibility to include in the system additional equipment and devices that ensure personnel safety.
- Do not modify this product.

WARNING**Use the Correct Power Supply**

Ensure that the source voltage matches the voltage of the power supply before turning ON the power.

Connect the Protective Grounding Terminal

Make sure to connect the protective grounding to prevent electric shock before turning ON the power.

Do Not Impair the Protective Grounding

Never cut off the internal or external protective earth wire or disconnect the wiring of the protective earth terminal. Doing so invalidates the protective functions of the instrument and poses a potential shock hazard.

Do Not Operate with Defective Protective Grounding or Fuse

Do not operate the instrument if the protective earth or fuse might be defective. Make sure to check them before operation.

Do Not Use in the Presence of Flammable Liquids, Vapors, and Dust

Do not use the instrument in the presence of flammable liquids, vapors, and dust. Operation in such environments constitutes a safety hazard.

Do Not Remove Covers

The cover should be removed by YOKOGAWA's qualified personnel only. Opening the cover is dangerous, because some areas inside the instrument have high voltages.

Ground the Instrument before Making External Connections

Connect the protective grounding before connecting to the item under measurement or to an external control unit.

Avoid Damage to the Protective Structure

Operating the instrument in a manner not described in this manual may damage its protective structure.

CAUTION

This instrument is a Class A product. Operation of this instrument in a residential area may cause radio interference, in which case the user is required to take appropriate measures to correct the interference.

Exemption from Responsibility

- YOKOGAWA makes no warranties regarding the product except those stated in the WARRANTY that is provided separately.
- YOKOGAWA assumes no liability to any party for any loss or damage, direct or indirect, caused by the user or any unpredictable defect of the product.

Software Handling Precautions

- YOKOGAWA makes no warranties regarding the software accompanying this product except those stated in the WARRANTY that is provided separately.
- Use the software on a single PC.
- You must purchase another copy of the software if you are to use the software on another PC.
- Copying the software for any purposes other than backup is strictly prohibited.
- Please store the original media containing the software in a safe place.
- Reverse engineering, such as decompiling of the software, is strictly prohibited.
- No portion of the software supplied by YOKOGAWA may be transferred, exchanged, sublet, or leased for use by any third party without prior permission by YOKOGAWA.

Conventions Used in This Manual

Unit

k	Denotes 1000.
K	Denotes 1024. Example: 5 KB (file size)

Safety Markings

The following markings are used in this manual.



Refer to corresponding location on the instrument. This symbol appears on dangerous locations on the instrument which require special instructions for proper handling or use. The same symbol appears in the corresponding place in the manual to identify those instructions.

WARNING

Calls attention to actions or conditions that could cause serious injury or death to the user, and precautions that can be taken to prevent such occurrences.

CAUTION

Calls attentions to actions or conditions that could cause light injury to the user or damage to the instrument or user's data, and precautions that can be taken to prevent such occurrences.

Note

Calls attention to information that is important for proper operation of the instrument.

Contents

Foreword	i
Safety Precautions	ii
Conventions Used in This Manual.....	iv

Chapter 1 Explanation of Functions

1.1	Overview of the MX100.....	1-1
	Main Module	1-2
	Input/Output Modules	1-2
	Base Plate	1-5
	PC Software.....	1-6
1.2	Main Module Functions.....	1-7
	Communications	1-7
	Measurement.....	1-7
	Filters	1-8
	Computation	1-8
	Remote RJC (RRJC)	1-8
	Alarms	1-9
	Contents Displayed on the 7-Segment LED	1-10
	Saving Data to the CF Card.....	1-11
1.3	Functions of the 4-CH, High-Speed Universal Input Module	1-14
	Input Type and Measurement Range	1-14
	Measurement Interval, Integration Time, and Filter	1-15
	Measurement Synchronization	1-15
	Common Mode Voltage	1-15
1.4	Functions of the 10-CH, Medium-Speed Universal Input Module	1-16
	Input Type and Measurement Range	1-16
	Measurement Interval, Integration Time, and Filter	1-17
	Measurement Synchronization	1-17
	Common Mode Voltage	1-17
1.5	Functions of the 30-CH, Medium-Speed DCV/TC/DI Input Module	1-18
	Input Type and Measurement Range	1-18
	Measurement Interval, Integration Time, and Filter	1-19
	Measurement Synchronization	1-19
	Common Mode Voltage	1-19
1.6	Functions of the 6-CH, Medium-Speed Four-Wire RTD Resistance Input Module.....	1-20
	Input Type and Measurement Range	1-20
	Measurement Interval, Integration Time, and Filter	1-21
	Measurement Synchronization	1-21
	Common Mode Voltage	1-21
1.7	Functions of the 4-CH, Medium-Speed Strain Input Module (-B12, -B35, and -NDI).....	1-22
	Measurement Range	1-22
	Measurement Interval, Integration Time, and Filter	1-22
	Measurement Synchronization	1-22
	Common Mode Voltage	1-22
	Initial Balancing (Initial Unbalance Value Adjustment).....	1-23
	Scaling Settings When Using a Strain Gauge Type Sensor	1-24
	Compensation When the Gauge Factor Differs.....	1-25

Contents

1.8	Functions of the 10-CH, High-Speed Digital Input Module (-D05, -D24)	1-26
	Measurement Interval	1-26
	Filters	1-26
1.9	Functions of the 8-CH, Medium-Speed Analog Output Module	1-27
	Output Type	1-27
	Output Range	1-27
	Output Update Interval.....	1-27
	Operation When Errors Occur upon Startup.....	1-27
	Output Operation During Calibration	1-27
1.10	Functions of the 8-CH, Medium-Speed PWM Output Module	1-28
	Output Type	1-28
	Output Waveform.....	1-28
	Pulse Interval	1-28
	Output Update Interval.....	1-28
	Output Range	1-28
	Operation When Errors Occur upon Startup.....	1-28
1.11	Operation of the 8-CH Medium-Speed Analog Output Module and the 8-CH Medium Speed PWM Output Module	1-29
	Output Selection When Errors Occur upon Startup.....	1-29
	Output Status.....	1-29
	Output on Disabled Channels.....	1-29
	Output Operation per Settings and Setting Changes	1-29
	Steady Output Operation.....	1-31
	Output When Abnormal, or after Recovery from Abnormality.....	1-32
1.12	Functions of the 10-CH, Medium-Speed Digital Output Module	1-35
	Output Type	1-35
	Output Update Interval.....	1-35
	Relay Action and Hold Behavior	1-35

Chapter 2 Installation and Wiring

2.1	Handling Precautions	2-1
2.2	Installation	2-2
	Installation Location	2-2
	Installation Procedure	2-2
⚠ 2.3	Attaching the Modules.....	2-4
	Attachment Procedure	2-4
	Attachment Positions and Channel Numbers	2-5
⚠ 2.4	Connecting the Signal Wires.....	2-6
	Terminal Arrangement Markings on the Terminal Cover.....	2-6
	Attaching and Removing the Terminal Block	2-7
	Attaching Plates with Screw Terminals and Plates with Clamped Terminals for Current..	2-8
	Screw Terminal Block	2-8
	General Precautions When Wiring the Input/Output Signal Wires	2-9
	Wiring Procedure	2-11
	Wiring the Universal Input Module and DCV/TC/DI Input Module	2-11
	Wiring the Four-Wire RTD Resistance Input Modules	2-12
	Wiring the Strain Input Modules.....	2-12
	Wiring the Digital Input Modules (-D05, -D24).....	2-16
	Wiring the Analog Output Modules	2-17
	Wiring the PWM Output Modules	2-17
	Wiring the Digital Output Modules	2-18

⚠ 2.5	Power Connection and ON/OFF	2-19
	Connections with the Power Cord (Power Supply/Cord Basic Specification Code 1□*)	2-19
	Wiring the Power Supply Terminal (Power Supply/Cord Basic Specification Code 1W)	2-20
	Turning ON/OFF the Power Switch	2-21
2.6	Connecting the Ethernet Cable	2-22
	Connection Procedure	2-22
	Checking the Communication Status	2-23
	Initializing the Settings	2-23
2.7	Measures against Noise on the MX100	2-24
	Integrating A/D Converter	2-24
	First-Order Lag Filter	2-26
2.8	Handling of the CF Card	2-27
	Handling Precautions of the CF Card	2-27
	Inserting the CF Card	2-27
	Ejecting the CF Card	2-27

Chapter 3 Troubleshooting and Maintenance

3.1	Error Display on the 7-Segment LED and Corrective Actions	3-1
	Errors at Power ON	3-1
	System Errors	3-1
	Module Errors	3-2
	Media-Related Errors	3-2
	Communication Errors	3-2
3.2	Troubleshooting	3-3
3.3	Calibration	3-6
	Range Calibration of DC Voltage, RTD, Resistance, Strain, and Analog Output	3-6
	Calibration of Temperature Measurements using Thermocouples	3-11
3.4	Maintenance of Parts	3-12
3.5	MX100 Maintenance and Test Using Communication Commands	3-13
	Connecting the Main Module and the PC	3-13
	Setting the Terminal Emulator	3-13
	List of Maintenance/Test Commands	3-13
	Specifications of the Maintenance/Test Port	3-13

Chapter 4 Specification

4.1	Common Specifications	4-1
4.2	Main Module Specifications	4-2
4.3	Base Plate Specifications	4-7
4.4	4-CH, High-Speed Universal Input Module Specifications	4-8
4.5	10-CH, Medium-Speed Universal Input Module Specifications	4-12
4.6	30-CH, Medium-Speed DCV/TC/DI Input Module Specifications	4-16
4.7	6-CH, Medium-Speed Four-Wire RTD Resistance Input Module Specifications	4-20
4.8	4-CH, Medium-Speed Strain Input Module Specifications	4-24
4.9	10-CH, High-Speed Digital Input Module Specifications	4-26
4.10	8-CH, Medium-Speed Analog Output Module Specifications	4-27
4.11	8-CH, Medium-Speed PWM Output Module Specifications	4-29
4.12	Operations Common to the 8-CH Medium-Speed Analog Output Module and the 8-CH Medium Speed PWM Output Module	4-32
4.13	10-CH, Medium-Speed Digital Output Module Specifications	4-33



Chapter 5 Dual Save Functions (/DS Option)

5.1	Overview of Functions.....	5-1
5.2	Explanation of Functions.....	5-2
5.3	CF Card Data File	5-9

Index

1.1 Overview of the MX100

The MX100 consists of the main module equipped with an Ethernet port, input/output modules that perform input or output of signals, and the base plate that attaches and connects all of these. By connecting the main module and a PC via the Ethernet interface and installing one of the dedicated software programs indicated below onto the PC, you can configure the acquisition conditions for the measured data from the PC as well as monitor and acquire the measured data on the PC. One to twenty MX100s can be connected to a single PC (one unit using the MX100 Standard Software, or one to twenty units (or up to 1200 input channels) using MXLOGGER).

One-to-one connection

- MX100 Standard Software
- MXLOGGER (sold separately)
- Software created using the API for the MX100/DARWIN (sold separately)

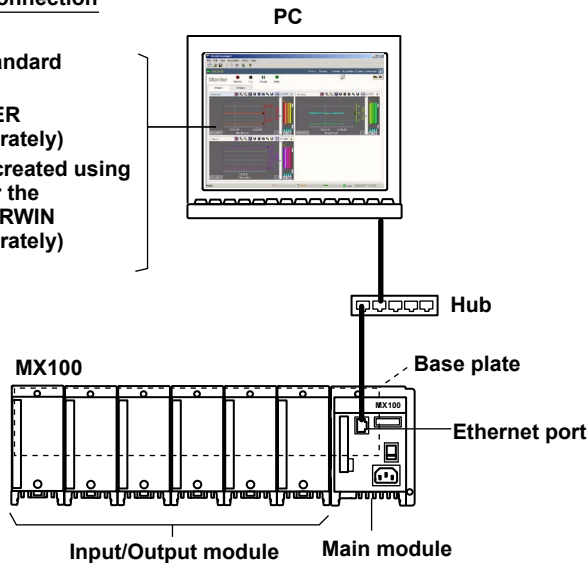

One-to-N connection

- MXLOGGER (sold separately)
- Software created using the API for the MX100/DARWIN (sold separately)

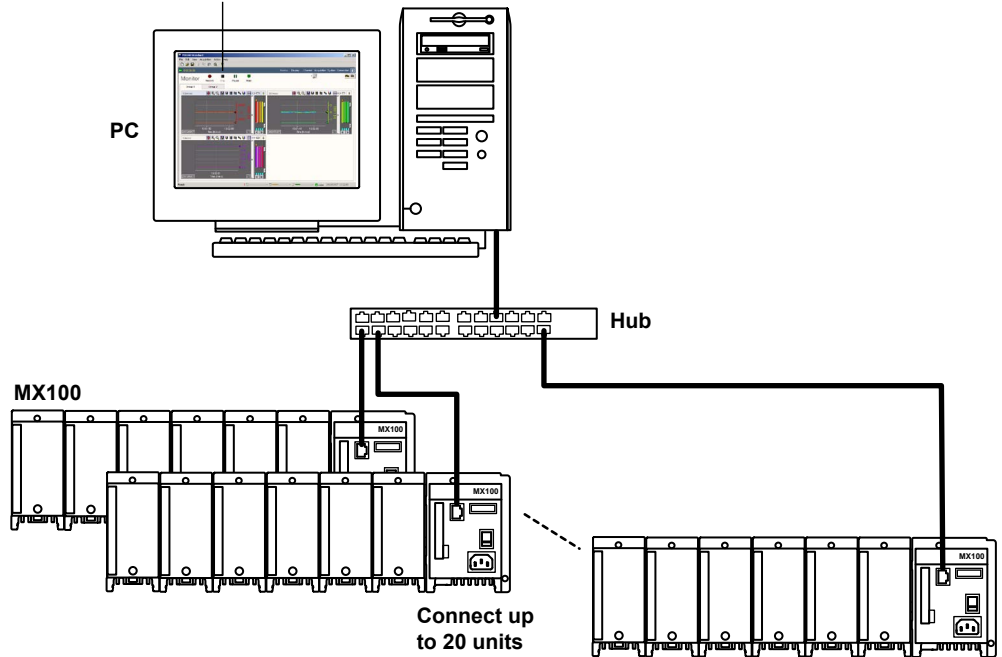

Main Module

The main module is equipped with a power supply connector, a power switch, an Ethernet port, a CF card slot, and other parts. It controls the power supply to and the control of each input/output module, communications with a PC, data storage to the CF card when communication is disconnected, and other functions.

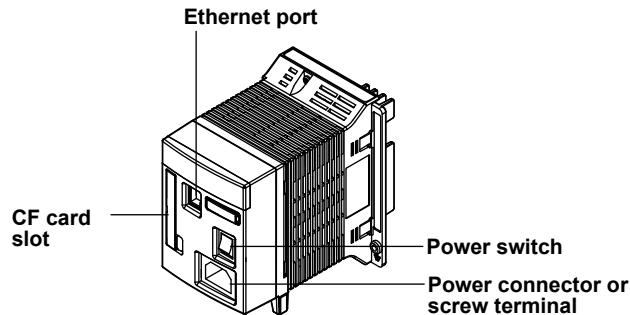

Input/Output Modules

The following twelve types of modules are available. A plate with screw terminals and separately installed screw terminal block (both sold separately) are available as accessories for the 10-CH, Medium-Speed Universal Input Module and the 10-CH, High-Speed Digital Input Module.

4-CH, High-Speed Universal Input Module (MX110-UNV-H04)

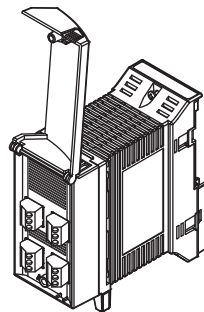

- Minimum measurement interval: 10 ms
- Maximum number of inputs: 4 inputs
- Input types: DC voltage, TC, 3-wire RTD, and DI (LEVEL, non-voltage contact)

10-CH, Medium-Speed Universal Input Module (MX110-UNV-M10)

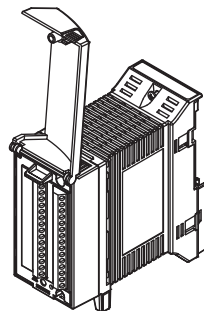

- Minimum measurement interval: 100 ms
- Maximum number of inputs: 10 inputs
- Input types: DC voltage, TC, 3-wire RTD, and DI (LEVEL, non-voltage contact)

30-CH, Medium-Speed DCV/TC/DI Input Module (MX110-VTD-L30, MX110-VTD-L30/H3)

- Minimum measurement interval: 500 ms
- Maximum number of inputs: 30 inputs
- Input types: DC voltage, TC, and DI (LEVEL, non-voltage contact)

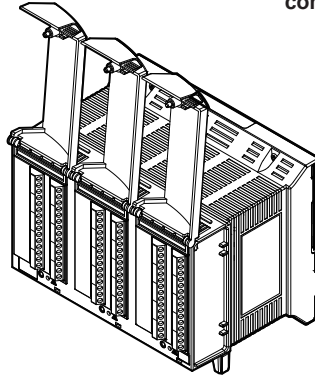

MX110-VTD-L30
(clamp terminal)

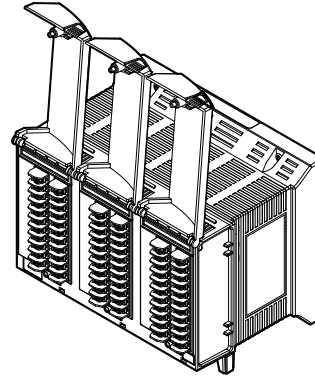

MX110-VTD-L30/H3
(M3 screw terminal)

6-CH, Medium-Speed Four-Wire RTD Resistance Input Module (MX110-V4R-M06)

- Minimum measurement interval: 100 ms
- Maximum number of inputs: 6 inputs
- Input types: DC voltage, 4-wire RTD, 4-wire resistance, and DI (LEVEL, non-voltage contact)

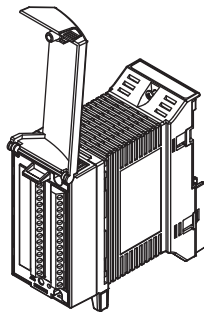

4-CH, Medium-Speed Strain Input Module (MX112-B12-M04, MX112-B35-M04)

- Minimum measurement interval: 100 ms
- Maximum number of inputs: 4 inputs
- Input system: floating balanced input (isolation between channels)

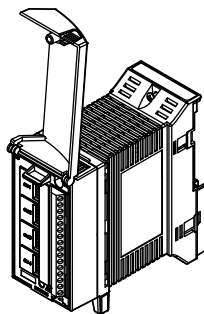

4-CH, Medium-Speed Strain Input Module (MX112-NDI-M04)

- Minimum measurement interval: 100 ms
- Maximum number of inputs: 4 inputs
- Input system: floating balanced input (non-isolation between channels)

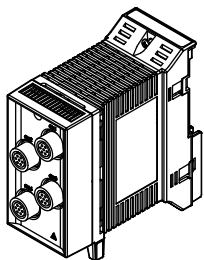

10-CH, High-Speed Digital Input Module (MX115-D05-H10)

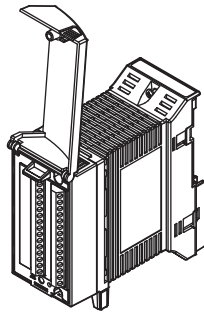

- Minimum measurement interval: 10 ms
- Maximum number of inputs: 10 inputs
- Input types: DI (non-voltage contact, open collector, and 5-V logic)

10-CH, High-Speed Digital Input Module (MX115-D24-H10)

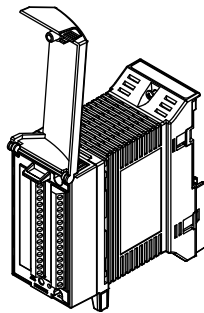

- Minimum measurement interval: 10 ms
- Maximum number of inputs: 10 inputs
- Input types: DI (24-V logic)

8-CH, Medium-Speed Analog Output Module (MX120-VAO-M08)

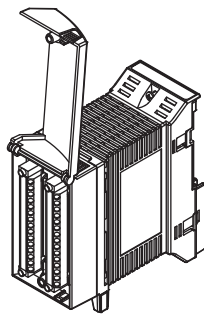

- Output update interval: 100 ms (shortest)
- Maximum number of inputs: 8 outputs
- Output type: DC voltage, DC current

8-CH, Medium-Speed PWM Output Module (MX120-PWM-M08)

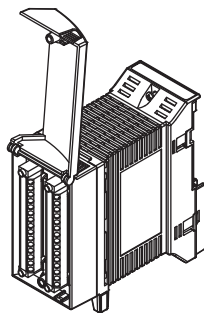

- Output update interval: 100 ms (shortest)
- Maximum number of inputs: 8 outputs
- Output type: PWM

10-CH, Medium-Speed Digital Output Module (MX125-MKC-M10)

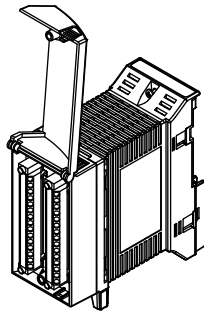

- Output update interval: 100 ms (shortest)
- Maximum number of outputs: 10 outputs
- Output type: A contact (SPST)

CAUTION

The 10-CH, Pulse Input Module (MX114-PLS-M10) cannot be used on the MX100 for the reasons below. Please use the 10-CH, Pulse Input Module with the MW100.

- Values measured on the MX100 are acquired by the MX100 Standard Software or MXLOGGER (sold separately).

Pulse measurement values are transferred to the PC software every measurement interval per the MX100 clock. For pulse integral values, pulse measurement values sent from the MX100 per the PC clock are integrated on the PC.

The error on the MX100 and PC clocks is different. Therefore discrepancies arise in the number of measurements and time, and the simultaneity of other measured values and pulse measured values is lost, along with the accuracy of pulse integral values.

Base Plate

The base plate is equipped with connectors for connecting the main module and input/output modules.

Six different base plates are available to hold one to six input/output modules. You can rack-mount or panel-mount the MX100 by attaching a DIN rail mount bracket to this base plate.

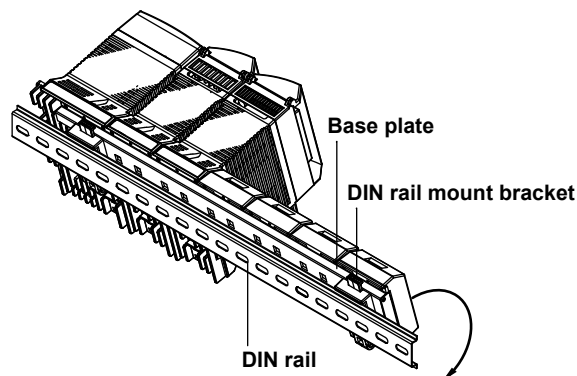

PC Software

One MX100 can be connected to a PC, and the MX100 Standard Software (that can acquire measured data) is included. The MX100 Standard Software consists of the three software programs below. For details about the software functions and operating procedures, see the MX100 Standard Software User's Manual. When configuring a system using the MX100, the software release number and hardware style number matching conditions must be met (see "Notes" on page i).

Integration Monitor

Enables you to connect or disconnect communications, configure acquisition conditions and display conditions of the measurement channels, set up computations channels, monitor measured and computed data, save measured and computed data, and carry out other operations.

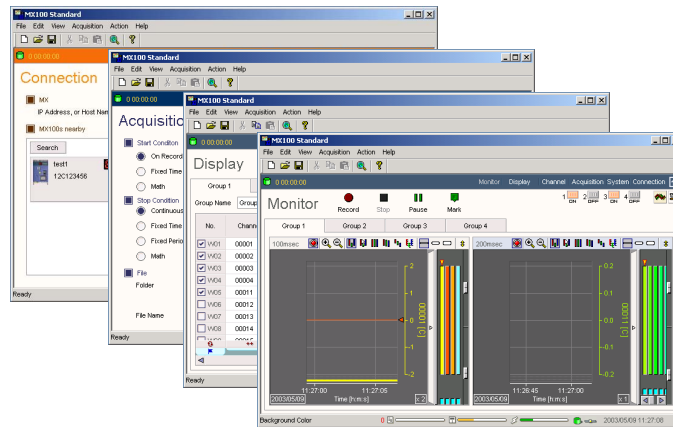

Viewer

Enables you to display measured and computed data that has been saved, read values and perform statistical computation over an area using cursors, and convert the measured and computed data into various file formats such as Excel.

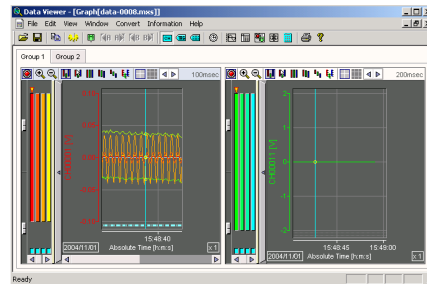

Calibrator

This program is used to calibrate the MX100 universal input modules, DCV/TC/DI input modules, 4-wire RTD resistance input module, strain input modules, and analog output module.

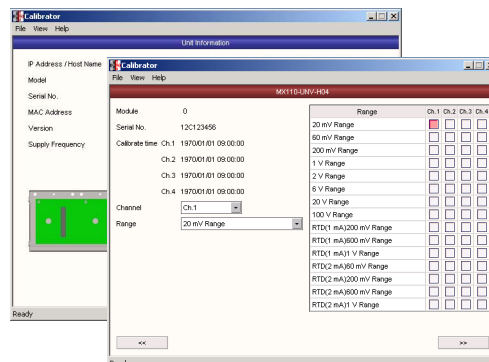

1.2 Main Module Functions

The main module is the heart of the MX100.

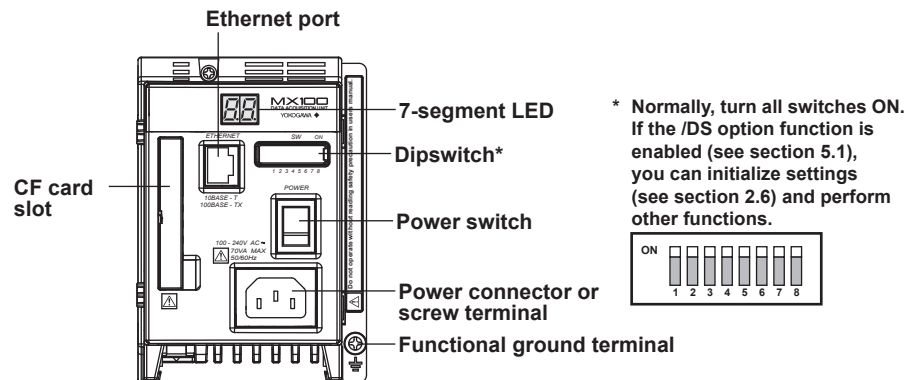

Communications

The main module is equipped with one auto-negotiating 10BASE-T/100BASE-TX Ethernet port. The LEDs at the upper-left and lower-left of the port indicate the communication status of the Ethernet interface.

Measurement

The main module acquires measured data sampled at specified intervals on each input module is acquired. Correcting computation, conversion to physical quantities, and other processes are performed on the acquired measured data, followed by transmission of measured data to a PC via the Ethernet interface at 100-ms intervals (shortest). Even if sampled at intervals less than 100 ms (10 ms or 50 ms), the data is transmitted collectively at 100-ms intervals. In addition, the main module receives output commands sent from the PC as necessary and generates signal output instructions to the output modules.

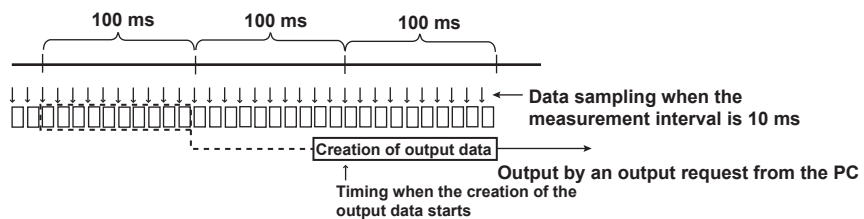

Synchronization of Measurements

- Synchronization between modules
If set to the same measurement interval, measurements made by input modules in the same acquisition unit are synchronized.
- Synchronization between channels
On the 4-CH, High-Speed Universal Input modules and 10-CH, high speed digital input modules (-D05 and -D24), measurements between channels are synchronized. On the 10-CH, Medium-Speed Universal Input modules, 30-CH, Medium-Speed DCV/TC/DI Input Modules, 6-CH Medium-Speed Four-Wire RTD Resistance Input modules, and 4-CH, Medium-Speed Strain Input modules (-B12, -B35, and -NDI), measurements are made sequentially one channel at a time. Therefore, measurements are not synchronized between channels (we can consider them synchronized within the measurement interval).

1.2 Main Module Functions

Measurement Time (When Using the MX100 Standard Software)

When a measurement start request or a measurement data output request is made by a PC to the main module, the PC's time information is transmitted to the main module. The main module generates measurement time using the internal clock based on the time when the measurement start request is received. When the measured data is sent to the PC, the PC's time information along with the measurement time information on the main module is returned to the PC. The time information used in the monitoring of the measured data on the PC is that of the main module. When measurement is made over an extended time, the time between the PC and main module may be misaligned (up to 60 seconds in one week excluding the accuracy of the PC clock). As a remedy to this problem, when the measured data is recorded (saved) on the PC, the PC's time information is stored along with the measurement time information on the main module. When the Viewer of the MX100 Standard Software is used to open the recorded measurement data, the "time synchronization" function can be used to correct the measurement time relative to the PC's time based on the PC's time information. For details on the time synchronization function, see the Technical Information, "MX100 Performance Specifications" (TI 04M08B01-00E). For information on obtaining a copy, contact your nearest YOKOGAWA dealer.

Filters

The main module is equipped with a first-order lag filter (see section 2.7, "Measures against Noise on the MX100"). You can select a time constant (time until 63.2% of the output value is reached) corresponding to the measurement interval indicated in the equation below.

Time constant = measurement interval × N (where N = 5, 10, 20, 25, 40, 50, or 100)

Computation

Difference computation between channels and linear scaling are possible. Linear scaling converts the measured values to values suitable for a particular purpose (scaled values) using the following equation.

$$\text{Scale value} = \frac{(X - SP_{\min}) \times (SC_{\max} - SC_{\min})}{SP_{\max} - SP_{\min}} + SC_{\min}$$

X: Measured value
SP_{max}: Specified span maximum
SP_{min}: Specified span minimum
SC_{max}: Specified scale maximum
SC_{min}: Specified scale minimum

Remote RJC (RRJC)

In measuring temperature with thermocouples within the same unit, when the item to be measured is located at a great distance, you can setup relay terminals near the item, measure the temperature of the relay terminal section using thermocouples (reference channel), and use the resultant value as the reference junction compensation value for the temperature measurement. By connecting a copper wire between the relay terminal and input terminal of the input module, and a thermocouple between the DUT and relay terminal, you can measure the temperature of the DUT without the need for a large amount of expensive thermocouples.

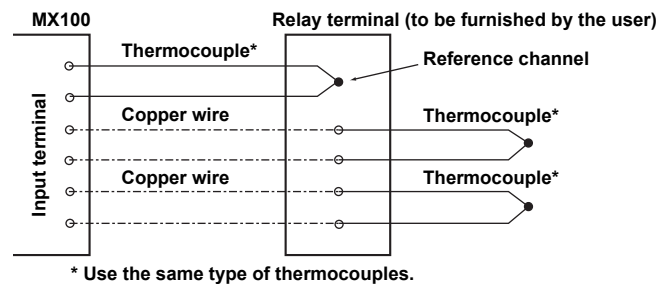

Alarms

This function outputs alarms when measured or computed values* meet certain conditions. Select up to four alarms of the following six types on each channel.

- **Upper limit alarm**
Generates an alarm when the measured or computed value* is greater than or equal to the alarm value.
- **Lower limit alarm**
Generates an alarm when the measured or computed value* is less than or equal to the alarm value.
- **Differential upper limit alarm**
Generates an alarm when differential input values (difference between the measured value of a channel and that of the reference channel) are greater than or equal to the alarm value.
- **Differential lower limit alarm**
Generates an alarm when differential input values (difference between the measured value of a channel and that of the reference channel) are less than or equal to the alarm value.
- **Upper limit on rate-of-change alarm***
Generates an alarm if the amount of change in the computed value in the rising direction exceeds the alarm value within the rate-of-change detection interval.
- **Lower limit on rate-of-change alarm***
Generates an alarm if the amount of change in the computed value in the falling direction exceeds the alarm value within the rate-of-change detection interval.

* When using computed value alarms, do not disconnect the MX100 and the PC software.
Alarms will not occur because the Computation function will not work on the MX100 by itself.

Alarm Value Hysteresis

You can set a width (hysteresis) to the values used to activate and release alarms. Alarm hysteresis can prevent frequent activation and release of alarms when the measured value is unstable around the alarm value.

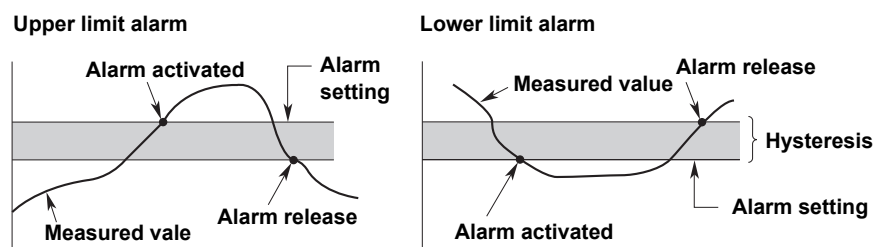

Alarm Output Timing

Alarms occur at each measurement interval based on the alarm settings. However when the measurement interval is 10 or 50 ms, alarms occur at 100 ms intervals based on all of the data.

Contents Displayed on the 7-Segment LED

The two-digit 7-segment LED displays the unit number, operating status, operation complete, and operation error of the MX100.

Unit Number Display

When connecting to the MX100 Standard Software, the unit number is fixed to 00 and displayed as “00.” When connecting to MXLOGGER (sold separately), the unit number is displayed as “00” to “19.”

Display of the Self-Test Operation at Power On

When the power is turned ON the dip switch indicator lights (normally displays “00”, or “0F” when the /DS option functions enabled), the operation ready indicator lights (the 88 display, and others), then the self-test is carried out. While the self-test is in progress, the following symbols are alternately displayed.

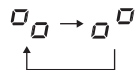

Operation Mode Hold Function Display (Only When the /DS Option Function is Installed)

Following the self-check, the /DS option function execution confirmation (“- -”) is displayed.

Operation Mode Display

The MX100 has three operation modes: idle mode, measurement mode, and backup mode (measured data saved to a CF card due to the disconnection of communications).

The modes are displayed as shown below. In the figure below, 00 indicates the unit number. If the unit number is not 00, the specified unit number is displayed.

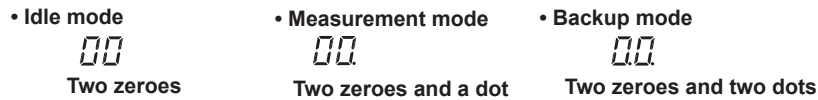

Display When Operation Is Complete

The figure below shows the display that appears when an operation such as IP address configuration and measurement condition change is completed. In the figure below, the unit number is “00.” If the unit number is not 00, the specified unit number is displayed.

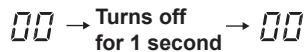

Display during Processing

The displays shown below repeats when the CF card is accessed, when the CF card is being formatted, or when calibration is taking place.

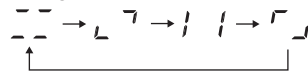

Unit Confirmation Display

The figure below shows the display that appears when you confirm the MX100 that is connected using the MX100 Standard Software or MXLOGGER (sold separately). The word -CALL- flows through the display from left to right.



Operation Error Display

For details on the display and meaning of errors, see section 3.1, “Error Display on the 7-Segment LED and Corrective Actions.”

Saving Data to the CF Card

Data Saving When Communication Is Disconnected and Dual Save Function

If communication is disconnected while the PC is recording (saving) measured data and a 60-s timeout* expires, the measured data is saved to the CF card at 60-s intervals.

When the save operation is started, a file is created for each measurement interval (referred to as the *monitor interval* on the MX100 Standard Software). As the save operation progresses and the file for the shortest measurement interval reaches 5 MB, the file is closed. At the same time, files of other measurement intervals (files that have not reached 5 MB) are also closed. Then, a new file is created for each measurement interval setting once again, and the save operation continues. When the communication with the PC resumes and acquisition of measured data resumes, the save operation automatically stops.

If the /DS option function (see “Saving Data to the CF Card” in section 5.1) is enabled, saving of measured data to the CF card is linked to recording on the PC, even if communication is disconnected.

To manually stop the operation, press the access stop switch (see “Ejecting the CF Card” in section 2.8) located above the CF card slot on the main module.

The table below shows the interval (a guideline) over which data can be saved to the CF card when one type of measurement interval is used.

* The time from the point when the communication between the PC and MX100 is disconnected and acquisition of measured data is stopped to the point when data storage to the CF card starts.

Number of Saved CHs	Measurement Interval	Capacity of the CF card						
		32 MB (6 files)	64 MB (12 files)	128 MB (34 files)	256 MB (49 files)	512 MB (98 files)	1 GB (196 files)	2 GB (390 files)
10 CHs	10 ms	2.1 hours	4.2 hours	8.7 hours	17.5 hours	35.3 hours	2.9 days	5.9 days
	50 ms	10.9 hours	21.8 hours	1.8 days	3.6 days	7.3 days	14 days	29 days
	100 ms	21.8 hours	1.8 days	3.6 days	7.2 days	14 days	29 days	59 days
	200 ms	1.8 days	3.6 days	7.2 days	14 days	29 days	59 days	118 days
	500 ms	4.5 days	9 days	18 days	36 days	73 days	147 days	295 days
	1 s	9 days	18 days	36 days	72 days	147 days	295 days	591 days
	2 s	18 days	36 days	72 days	145 days	294 days	591 days	1182 days
24 CHs	10 ms	54 min.	1.8 hours	3.6 hours	7.3 hours	14.7 hours	29.5 hours	2.4 days
	50 ms	4.5 hours	9 hours	18 hours	1.5 days	3 days	6.1 days	12 days
	100 ms	9 hours	18 hours	1.5 days	3 days	6.1 days	12 days	24 days
	200 ms	18.1 hours	1.5 days	3 days	6.1 days	12 days	24 days	49 days
	500 ms	1.8 days	3.7 days	7.5 days	15 days	30 days	61 days	122 days
	1 s	3.7 days	7.5 days	15 days	30 days	61 days	123 days	246 days
	2 s	7.5 days	15 days	30 days	60 days	122 days	246 days	492 days
60 CHs	10 ms	21 min.	42 min.	1.4 hours	2.9 hours	5.8 hours	11.7 hours	23.4 hours
	50 ms	1.8 hours	3.6 hours	7.2 hours	14.7 hours	29.4 hours	2.4 days	4.9 days
	100 ms	3.6 hours	7.2 hours	14.4 hours	29.4 hours	2.4 days	4.9 days	9.8 days
	200 ms	7.2 hours	14.4 hours	28.8 hours	2.4 days	4.9 days	9.8 days	19 days
	500 ms	18.1 hours	1.5 days	3 days	6 days	12 days	24 days	49 days
	1 s	1.5 days	3 days	6 days	12 days	24 days	49 days	98 days
	2 s	3 days	6 days	12 days	24 days	49 days	98 days	196 days

File Structure and Saved Channels

A file is created on the CF card for every measurement interval. The measurement interval is the one specified as the monitor interval under Measurement Group in the Acquisition Conditions screen of the MX100 Standard Software (not the recording interval).

Measurement groups of the same monitoring interval are saved to the same file.

The channels saved to the file are those whose Monitor check boxes are selected in the Channel screen (not those whose Record check boxes are selected). For other specifications relating to saving of data, see “Data Storage” in section 4.2.

Precautions When Using the CF Card

On the MX100, measured data can only be saved to the CF card (backed up) when recording of measured data to the PC via communications is turned OFF (unless the /DS option function is active). In this case, saving of data to the CF card presumes that the following conditions are met.

• **Checking the CF Card Status**

Before starting recording, check that the CF card is inserted into the slot, the installation status is “Exists,” and that “Usable” is “Yes.”

When using the MX100 Standard Software, check that the Status display under CF Card Information in the System screen is “Exists (Usable).” See “Explanation” in section 2.2 of the MX100 Standard Software User’s Manual (IMMX180-01E).

When using the API for MX100/DARWIN, check the installation status and usability by sending the status request command (getStatusDataMX).

Note

- If data saving has been restored after being disabled, due to a media-related error, check that the installation status is “Exists,” and that Usable is “Yes.”
- If the CF card is inserted during recording and the installation status is “Exists” but Usable is “No,” data cannot be saved (example 3 in the CF card operation diagram below).

• **Operation of the CF Card**

If you press the access stop switch (see “Ejecting the CF Card” in section 2.8) during recording, data is not saved to the CF card even if communication is disconnected.

MX100 Operation and Status Relative to CF Card Operation

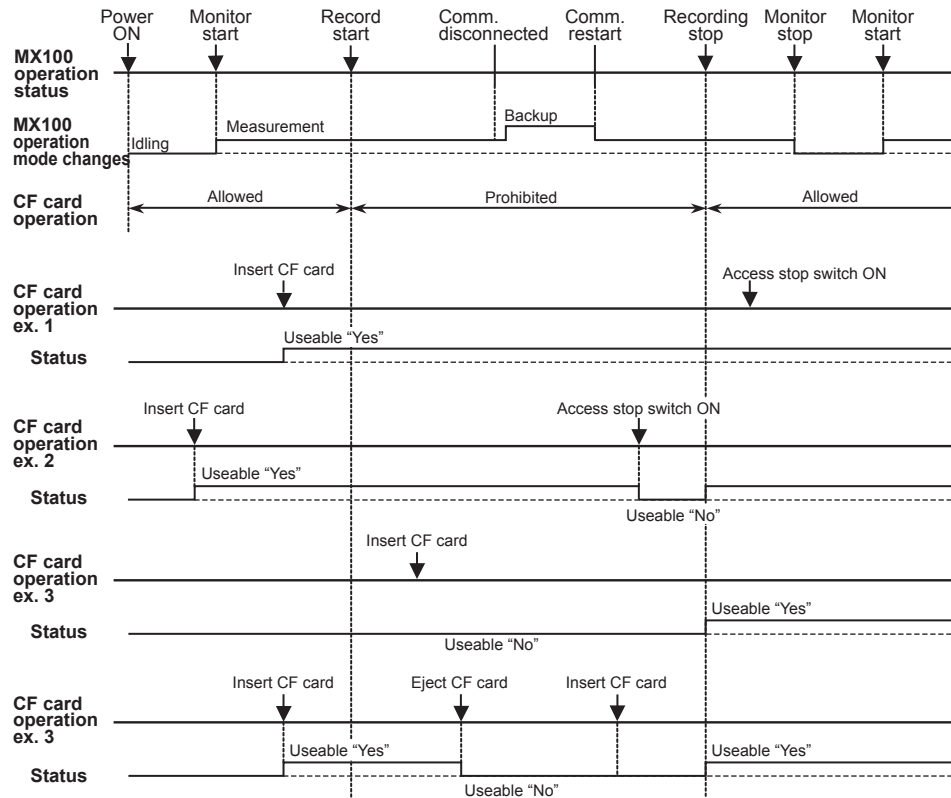

Log File Storage

In addition to the measured data that is saved when the communication with the PC is disconnected, a log file of information related to the CF card operation and information of power ON/OFF is saved to the CF card in text format (MX100MLG.TXT). The maximum size of the log file is 40 KB. Up to 1021 events can be stored. When 1021 events are exceeded, the event is deleted in order from the oldest information. The log is written (overwritten to the same file name) to the CF card when you press the access stop switch (see "Ejecting the CF Card" in section 2.8).

Information Saved to the Log File

- Date/Time when the power is turn ON or OFF.
- Date/Time when the CF card is inserted or ejected.
- Save mode when data is saved (backup) and the start/stop log.
- The file creation and deletion log.
- Media-related errors.
- The CF card formatting log.

Log File Example

Yokogawa DAQMASTER MX100 <Media Info>			
Date	Time	Status	Message
70/01/01	00:00:00	Power	off
03/01/01	00:00:01	Power	on
03/03/25	10:12:13	Format	ok
03/03/25	11:14:12	Backup	start
03/03/25	11:14:12	Mode	rotary
03/03/25	11:14:13	Delete	(--)
03/03/25	11:14:21	Create	32500000
03/03/25	11:14:36	Code	12 MF
03/03/25	11:14:36	Error	P3
03/03/25	11:14:54	Backup	stop
03/03/25	11:15:18	Create	MX100MLG
03/03/25	11:15:22	Card	out
03/03/25	11:15:25	Card	in
>>			

Time indicating that the settings have been initialized*

Time after resetting the internal clock*

Media error (records the error code)

Most-recent information

Termination mark

* When the MX100 is initialized, the date/time on the MX100 is reset to 1970/01/01 00:00:00 once, then to the default value on the MX100 (2003/01/01 00:00:00). Then, when the PC software is started and connection to the MX100 is made, the current date/time on the PC is transmitted to the MX100. The MX100 is reset to the received date/time.

CF Card Specifications

Item	Specification
Capacity	2 GB maximum
Type	Type I or Type II
Format	Supports quick (logical) format. 1 partition format (hard disk format) is possible only through a command from the PC when the MX operation mode is idle.
File system	FAT or FAT16

1.3 Functions of the 4-CH, High-Speed Universal Input Module

This module is equipped with four inputs and measures DC voltage, Thermocouple, three-wire RTD, and digital input (DI) at a minimum measurement interval of 10 ms.

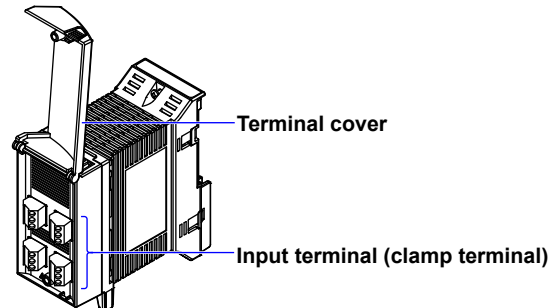

Input Type and Measurement Range

The following measurements are possible.

Input	Measurement Range Type	Rated Measurement Range
DC voltage	20 mV	-20.000 to 20.000 mV
	60 mV	-60.00 to 60.00 mV
	200 mV	-200.00 to 200.00 mV
	2 V	-2.0000 to 2.0000 V
	6 V	-6.000 to 6.000 V
	20 V	-20.000 to 20.000 V
	100 V	-100.00 to 100.00 V
Thermocouple	R	0.0 to 1760.0°C
	S	
	B	0.0 to 1820.0°C
	K	-200.0 to 1370.0°C
	E	-200.0 to 800.0°C
	J	-200.0 to 1100.0°C
	T	-200.0 to 400.0°C
	N	0.0 to 1300.0°C
	W	0.0 to 2315.0°C
	L	-200.0 to 900.0°C
	U	-200.0 to 400.0°C
RTD (Measurement current: 1 mA)	KPvsAu7Fe	0.0 to 300.0K
	Pt100	-200.0 to 600.0°C
	JPt100	-200.0 to 550.0°C
	Pt100 (high resolution)	-140.00 to 150.00°C
	JPt100 (high resolution)	-140.00 to 150.00°C
	Ni100 SAMA	-200.0 to 250.0°C
	Ni100 DIN	-60.0 to 180.0°C
RTD (Measurement current: 2 mA)	Ni120	-70.0 to 200.0°C
	Pt100	-200.0 to 250.0°C
	JPt100	-200.0 to 250.0°C
	Pt100 (high resolution)	-140.00 to 150.00°C
	JPt100 (high resolution)	-140.00 to 150.00°C
	Pt50	-200.0 to 550.0°C
	Cu10 GE	-200.0 to 300.0°C
	Cu10 L&N	-200.0 to 300.0°C
	Cu10 WEED	-200.0 to 300.0°C
Cu10 BAILEY	-200.0 to 300.0°C	
DI	J263B	0.0 to 300.0K
	Level	V _{th} = 2.4 V
	Contact input	ON: 100 Ω or less, OFF: 10 kΩ or more

1.3 Functions of the 4-CH, High-Speed Universal Input Module

The following inputs can be used on MXLOGGER or MX100/DARWIN API sold separately. These inputs cannot be used with the MX100 Standard Software.

Input	Measurement Range Type	Rated Measurement Range
DC voltage	60 mV (high resolution)	0.000 to 60.000 mV
	1 V	-1.0000 to 1.0000 V
	6 V (high resolution)	0.0000 to 6.0000 V
Thermocouple	PLATINEL	0.0 to 1400.0°C
	PR40-20	0.0 to 1900.0°C
	NiNiMo	0.0 to 1310.0°C
	WRe3-25	0.0 to 2400.0°C
	W/WRe26	0.0 to 2400.0°C
	N (AWG14)	0.0 to 1300.0°C
	XK GOST	-200.0 to 600.0°C
RTD (Measurement current: 1 mA)	Pt100 (noise resistance)	-200.0 to 600.0°C
	JPt100 (noise resistance)	-200.0 to 550.0°C
	Pt100 GOST	-200.0 to 600.0°C
RTD (Measurement current: 2 mA)	Cu10 at 20°C alpha = 0.00392	-200.0 to 300.0°C
	Cu10 at 20°C alpha = 0.00393	-200.0 to 300.0°C
	Cu25 at 0°C alpha = 0.00425	-200.0 to 300.0°C
	Cu53 at 0°C alpha = 0.00426035	-50.0 to 150.0°C
	Cu100 at 0°C alpha = 0.00425	-50.0 to 150.0°C
	Pt25 (JPt100 × 1/4)	-200.0 to 550.0°C
	Cu10 GE (high resolution)	-200.0 to 300.0°C
	Cu10 L&N (high resolution)	-200.0 to 300.0°C
	Cu10 WEED (high resolution)	-200.0 to 300.0°C
	Cu10 BAILEY (high resolution)	-200.0 to 300.0°C
	Pt100 (noise resistance)	-200.0 to 250.0°C
	JPt100 (noise resistance)	-200.0 to 250.0°C
	Cu100 GOST	-200.0 to 200.0°C
	Cu50 GOST	-200.0 to 200.0°C
	Cu10 GOST	-200.0 to 200.0°C

Measurement Interval, Integration Time, and Filter

The table below shows the available measurement intervals. The module is equipped with an integrating A/D converter. The selectable integration time varies depending on the measurement interval as shown in the table below. For details about the relationship between noise and integration time, see section 2.7, "Measures against Noise on the MX100" In addition, the type of noise rejection filter switches as shown in the table below.

Measurement Interval	Integration Time	Filter	Rejected Noise and Notes
10 ms	1.67 ms	Rectangular	600 Hz and its integer multiples*
50 ms	16.67 ms		60 Hz and its integer multiples
	20 ms		50 Hz and its integer multiples
	Auto		Automatically detects the power supply frequency and set 16.67 or 20 ms
100, 200 ms	36.67 ms	Trapezoidal	50 Hz or 60 Hz and their integer multiples
500 ms	100 ms	Rectangular	10 Hz and its integer multiples
1, 2, 5, 10, 20, 30, 60 s	200 ms	Cos	Fc = 5-Hz low-pass filter

* Since the power supply frequency noise is not rejected, the measured vales may fluctuate especially with temperature measurement. In such cases, set the measurement interval to 50 ms or higher.

Measurement Synchronization

Each input channel has its own A/D converter. Therefore, measurements on each channel are synchronized.

Common Mode Voltage

The common mode voltage between channels in a single module is 250 VACrms when the signal is applied continuously.

The common mode voltage between modules and between a module and earth is 600 VACrms when the signal is applied continuously.

1.4 Functions of the 10-CH, Medium-Speed Universal Input Module

This module is equipped with ten inputs and measures DC voltage, Thermocouple, three-wire RTD, and digital input (DI) at a minimum measurement interval of 100 ms.

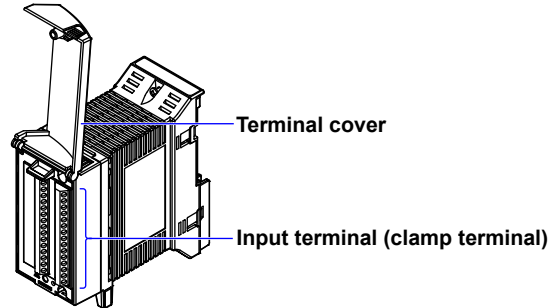

Input Type and Measurement Range

The following measurements are possible.

Input	Measurement Range Type	Rated Measurement Range
DC voltage	20 mV	-20.000 to 20.000 mV
	60 mV	-60.00 to 60.00 mV
	200 mV	-200.00 to 200.00 mV
	2 V	-2.0000 to 2.0000 V
	6 V	-6.000 to 6.000 V
	20 V	-20.000 to 20.000 V
	100 V	-100.00 to 100.00 V
Thermocouple	R	0.0 to 1760.0°C
	S	
	B	0.0 to 1820.0°C
	K	-200.0 to 1370.0°C
	E	-200.0 to 800.0°C
	J	-200.0 to 1100.0°C
	T	-200.0 to 400.0°C
	N	0.0 to 1300.0°C
	W	0.0 to 2315.0°C
	L	-200.0 to 900.0°C
	U	-200.0 to 400.0°C
	KPvsAu7Fe	0.0 to 300.0K
RTD (Measurement current: 1 mA)	Pt100	-200.0 to 600.0°C
	JPt100	-200.0 to 550.0°C
	Pt100 (high resolution)	-140.00 to 150.00°C
	JPt100 (high resolution)	-140.00 to 150.00°C
	Ni100 SAMA	-200.0 to 250.0°C
	Ni100 DIN	-60.0 to 180.0°C
	Ni120	-70.0 to 200.0°C
	Pt50	-200.0 to 550.0°C
	Cu10 GE	-200.0 to 300.0°C
	Cu10 L&N	-200.0 to 300.0°C
	Cu10 WEED	-200.0 to 300.0°C
	Cu10 BAILEY	-200.0 to 300.0°C
	J263B	0.0 to 300.0K
DI	Level	V _{th} = 2.4 V
	Contact input	ON: 1 kΩ or less, OFF: 100 kΩ or more (parallel capacitance: 0.01 μF or less)

The following inputs can be used on MXLOGGER or the MX100/DARWIN API (sold separately). These inputs cannot be used with the MX100 Standard Software.

Input	Measurement Range Type	Rated Measurement Range
DC voltage	60 mV (high resolution)	0.000 to 60.000 mV
	1 V	-1.0000 to 1.0000 V
	6 V (high resolution)	0.0000 to 6.0000 V
Thermocouple	PLATINEL	0.0 to 1400.0°C
	PR40-20	0.0 to 1900.0°C
	NiNiMo	0.0 to 1310.0°C
	WRe3-25	0.0 to 2400.0°C
	W/WRe26	0.0 to 2400.0°C
	N (AWG14)	0.0 to 1300.0°C
	XK GOST	-200.0 to 600.0°C
RTD (Measurement current: 1 mA)	Cu10 at 20°C alpha = 0.00392	-200.0 to 300.0°C
	Cu10 at 20°C alpha = 0.00393	-200.0 to 300.0°C
	Cu25 at 0°C alpha = 0.00425	-200.0 to 300.0°C
	Cu53 at 0°C alpha = 0.00426035	-50.0 to 150.0°C
	Cu100 at 0°C alpha = 0.00425	-50.0 to 150.0°C
	Pt25 (JPt100 × 1/4)	-200.0 to 550.0°C
	Cu10 GE (high resolution)	-200.0 to 300.0°C
	Cu10 L&N (high resolution)	-200.0 to 300.0°C
	Cu10 WEED (high resolution)	-200.0 to 300.0°C
	Cu10 BAILEY (high resolution)	-200.0 to 300.0°C
	Pt100 GOST	-200.0 to 600.0°C
	Cu100 GOST	-200.0 to 200.0°C
	Cu50 GOST	-200.0 to 200.0°C
	Cu10 GOST	-200.0 to 200.0°C

Measurement Interval, Integration Time, and Filter

The table below shows the available measurement intervals. The module is equipped with an integrating A/D converter. The selectable integration time varies depending on the measurement interval as shown in the table below. For details about the relationship between noise and integration time, see section 2.7, “Measures against Noise on the MX100” In addition, the type of noise rejection filter switches as shown in the table below.

Measurement Interval	Integration Time	Burnout Detection Cycle	Filter	Rejected Noise and Notes
100 ms	1.67 ms	1 s ⁻¹	Rectangular	600 Hz and its integer multiples ^{*2}
200 ms		Measurement interval		60 Hz and its integer multiples
500 ms	16.67 ms			50 Hz and its integer multiples
	20 ms			Automatically detects the power supply frequency and set 16.67 or 20 ms
1 s	36.67 ms		Trapezoidal	50 Hz or 60 Hz and their integer multiples
2 s	100 ms		Rectangular	10 Hz and its integer multiples
5, 10, 20, 30, 60 s	200 ms		Cos	Fc = 5-Hz low-pass filter

*1 If the measurement interval is 100 ms, burnout detection is carried out on a single channel during one measurement interval. Therefore, when starting measurement during the burnout condition or thereafter, burnout can be detected for up to 10 measurements (approximately 1 second).

*2 Since the power supply frequency noise is not rejected, the measured values may fluctuate especially with temperature measurement. In such cases, set the measurement interval to 500 ms or higher, or use the 4-CH, High-Speed Universal Input Module.

Measurement Synchronization

The module is equipped with a single A/D converter, and measurement is made sequentially. Therefore, measurements of each channel are not synchronized.

Common Mode Voltage

The common mode voltage between channels in a single module is 120 VACrms when the signal is applied continuously. The common mode voltage between modules and between a module and earth is 600 VACrms when the signal is applied continuously.

1.5 Functions of the 30-CH, Medium-Speed DCV/TC/DI Input Module

This module is equipped with 30 inputs and measures DC voltage, Thermocouple, and digital input (DI) at a minimum measurement interval of 500 ms. It takes up three modules worth of space when attaching to the base plate.

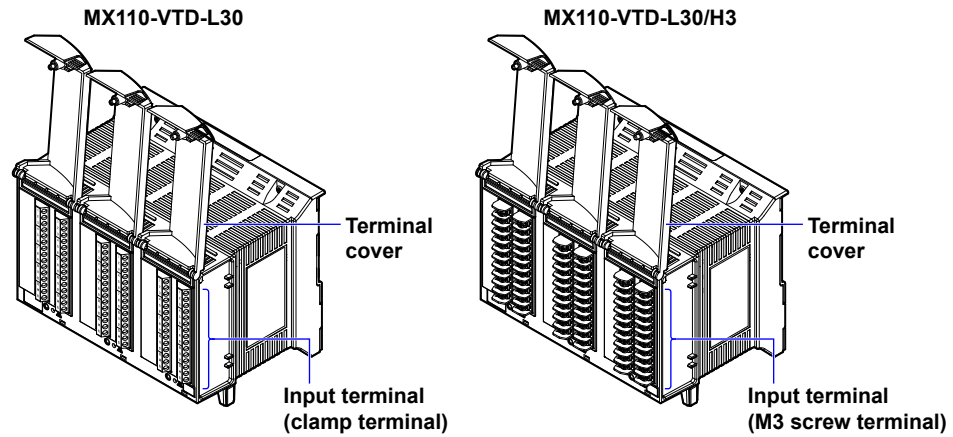

Input Type and Measurement Range

The following measurements are possible.

Input	Measurement Range Type	Rated Measurement Range
DC voltage	20 mV	-20.000 to 20.000 mV
	60 mV	-60.00 to 60.00 mV
	200 mV	-200.00 to 200.00 mV
	2 V	-2.0000 to 2.0000 V
	6 V	-6.000 to 6.000 V
	20 V	-20.000 to 20.000 V
	100 V	-100.00 to 100.00 V
Thermocouple	R	0.0 to 1760.0°C
	S	
	B	0.0 to 1820.0°C
	K	-200.0 to 1370.0°C
	E	-200.0 to 800.0°C
	J	-200.0 to 1100.0°C
	T	-200.0 to 400.0°C
	N	0.0 to 1300.0°C
	W	0.0 to 2315.0°C
	L	-200.0 to 900.0°C
	U	-200.0 to 400.0°C
DI	KPvsAu7Fe	0.0 to 300.0K
	Level	V _{th} = 2.4 V
	Contact input	ON: 1 kΩ or less, OFF: 100 kΩ or more (parallel capacitance: 0.01 μF or less)

1.5 Functions of the 30-CH, Medium-Speed DCV/TC/DI Input Module

The following inputs can be used on MXLOGGER or the MX100/DARWIN API (sold separately). These inputs cannot be used with the MX100 Standard Software.

Input	Measurement Range Type	Rated Measurement Range
DC voltage	60 mV (high resolution)	0.000 to 60.000 mV
	1 V	-1.0000 to 1.0000 V
	6 V (high resolution)	0.0000 to 6.0000 V
Thermocouple	PLATINEL	0.0 to 1400.0°C
	PR40-20	0.0 to 1900.0°C
	NiNiMo	0.0 to 1310.0°C
	WRe3-25	0.0 to 2400.0°C
	W/WRe26	0.0 to 2400.0°C
	N (AWG14)	0.0 to 1300.0°C
	XK GOST	-200.0 to 600.0°C

Measurement Interval, Integration Time, and Filter

The table below shows the available measurement intervals. The module is equipped with an integrating A/D converter. The selectable integration time varies depending on the measurement interval as shown in the table below. For details about the relationship between noise and integration time, see section 2.7, “Measures against Noise on the MX100” In addition, the type of noise rejection filter switches as shown in the table below.

Measurement Interval	Integration Time	Filter	Rejected Noise and Notes
500 ms	1.67 ms	Rectangular	600 Hz and its integer multiples*
1 s	16.67 ms		60 Hz and its integer multiples
	20 ms		50 Hz and its integer multiples
	Auto		Automatically detects the power supply frequency and set 16.67 or 20 ms
2 s	36.67 ms	Trapezoidal	50 Hz or 60 Hz and their integer multiples
5, 10, 20, 30, 60 s	100 ms	Rectangular	10 Hz and its integer multiples

* Since the power supply frequency noise is not rejected, the measured values may fluctuate especially with temperature measurement. In such cases, set the measurement interval to 1 s or higher, or use the 4-CH, High-Speed Universal Input Module or the 10-CH, Medium-Speed Universal Input Module.

Measurement Synchronization

The module is equipped with a single A/D converter, and measurement is made sequentially. Therefore, measurements of each channel are not synchronized.

Common Mode Voltage

The common mode voltage between channels in a single module is 120 VACrms when the signal is applied continuously. The common mode voltage between modules and between a module and earth is 600 VACrms when the signal is applied continuously.

1.6 Functions of the 6-CH, Medium-Speed Four-Wire RTD Resistance Input Module

This module is equipped with six inputs and measures DC voltage, four-wire RTD, four-wire resistance, and digital input (DI) at a minimum measurement interval of 100 ms.

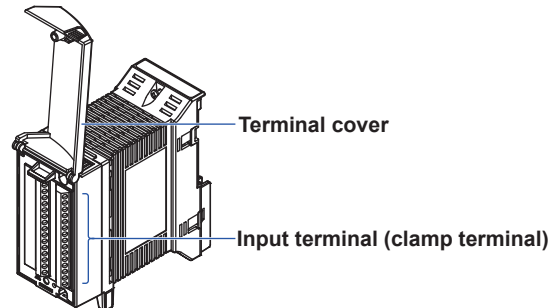

Input Type and Measurement Range

The following measurements are possible.

Input	Measurement Range Type	Rated Measurement Range
DC voltage	20 mV	-20.000 to 20.000 mV
	60 mV	-60.00 to 60.00 mV
	200 mV	-200.00 to 200.00 mV
	2 V	-2.0000 to 2.0000 V
	6 V	-6.000 to 6.000 V
	20 V	-20.000 to 20.000 V
	100 V	-100.00 to 100.00 V
RTD* ¹ (Measurement current: 1 mA)	Pt100	-200.0 to 600.0°C
	JPt100	-200.0 to 550.0°C
	Pt100 (high resolution)	-140.00 to 150.00°C
	JPt100 (high resolution)	-140.00 to 150.00°C
	Ni100 SAMA	-200.0 to 250.0°C
	Ni100 DIN	-60.0 to 180.0°C
	Ni120	-70.0 to 200.0°C
	Pt50	-200.0 to 550.0°C
	Cu10 GE	-200.0 to 300.0°C
	Cu10 L&N	-200.0 to 300.0°C
	Cu10 WEED	-200.0 to 300.0°C
	Cu10 BAILEY	-200.0 to 300.0°C
	J263B	0.0 to 300.0K
DI	Level	V _{th} = 2.4 V
	Contact input	ON: 1 kΩ or less, OFF: 100 kΩ or more (parallel capacitance: 0.01 μF or less)
RTD* ^{1, 2} (Measurement current: 0.25 mA)	Pt500	-200.0 to 600.0°C
	Pt1000	-200.0 to 600.0°C
Resistance* ¹	20 Ω (Measurement current: 1 mA)	0.000 to 20.000 Ω
	200 Ω (Measurement current: 1 mA)	0.00 to 200.00 Ω
	2 kΩ (Measurement current: 0.25 mA)	0.0 to 2000.0 Ω

*1 RTD and resistance are all 4-wire measurements

*2 The Pt500 resistance table is Pt100 × 5, and the resistance table for Pt1000 is Pt100 × 10

1.6 Functions of the 6-CH, Medium-Speed Four-Wire RTD Resistance Input Module

The following inputs can be used on MXLOGGER or the MX100/DARWIN API (sold separately). These inputs cannot be used with the MX100 Standard Software.

Input	Measurement Range Type	Rated Measurement Range
DC voltage	60 mV (high resolution)	0.000 to 60.000 mV
	1 V	-1.0000 to 1.0000 V
	6 V (high resolution)	0.0000 to 6.0000 V
RTD (Measurement current: 1 mA)	Cu10 at 20°C alpha = 0.00392	-200.0 to 300.0°C
	Cu10 at 20°C alpha = 0.00393	-200.0 to 300.0°C
	Cu25 at 0°C alpha = 0.00425	-200.0 to 300.0°C
	Cu53 at 0°C alpha = 0.00426035	-50.0 to 150.0°C
	Cu100 at 0°C alpha = 0.00425	-50.0 to 150.0°C
	Pt25 (JPt100 × 1/4)	-200.0 to 550.0°C
	Cu10 GE (high resolution)	-200.0 to 300.0°C
	Cu10 L&N (high resolution)	-200.0 to 300.0°C
	Cu10 WEED (high resolution)	-200.0 to 300.0°C
	Cu10 BAILEY (high resolution)	-200.0 to 300.0°C
	Pt100 GOST	-200.0 to 600.0°C
	Cu100 GOST	-200.0 to 200.0°C
	Cu50 GOST	-200.0 to 200.0°C
	Cu10 GOST	-200.0 to 200.0°C

Measurement Interval, Integration Time, and Filter

The table below shows the available measurement intervals. The module is equipped with an integrating A/D converter. The selectable integration time varies depending on the measurement interval as shown in the table below. For details about the relationship between noise and integration time, see section 2.7, "Measures against Noise on the MX100" In addition, the type of noise rejection filter switches as shown in the table below.

Measurement Interval	Integration Time	Filter	Rejected Noise and Notes
100, 200 ms	1.67 ms	Rectangular	600 Hz and its integer multiples*
500 ms	16.67 ms		60 Hz and its integer multiples
	20 ms		50 Hz and its integer multiples
	Auto		Automatically detects the power supply frequency and set 16.67 or 20 ms
1 s	36.67 ms	Trapezoidal	50 Hz or 60 Hz and their integer multiples
2 s	100 ms	Rectangular	10 Hz and its integer multiples
5, 10, 20, 30, 60 s	200 ms	Cos	Fc = 5-Hz low-pass filter

* Since the power supply frequency noise is not rejected, the measured values may fluctuate especially with temperature measurement and 20 Ω measurement. In such cases, set the measurement interval to 500 ms or higher.

Measurement Synchronization

The module is equipped with a single A/D converter, and measurement is made sequentially. Therefore, measurements of each channel are not synchronized.

Common Mode Voltage

The common mode voltage between channels in a single module when applied continuously is 120 VACrms, and the resistance for RTD is 50 VACrms.

The common mode voltage between modules and between a module and earth is 600 VACrms when the signal is applied continuously.

1.7 Functions of the 4-CH, Medium-Speed Strain Input Module (-B12, -B35, and -NDI)

This module is equipped with four inputs and measures strain from strain gauges and from strain gauge type sensors at a minimum measurement interval of 100 ms.

-B12, -B35

-NDI

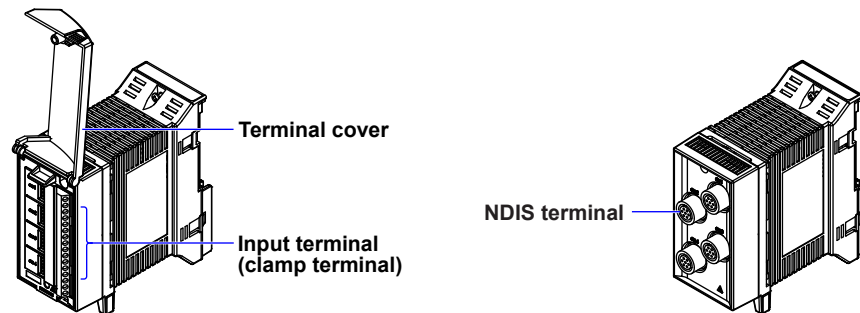

Measurement Range

Input	Measurement Range Type	Rated Measurement Range
Strain	2000 μ Strain	-2000.0 to +2000.0 μ Strain
	20000 μ Strain	-20000 to +20000 μ Strain
	200000 μ Strain	-200000 to +200000 μ Strain

Measurement Interval, Integration Time, and Filter

Measurement Interval	Integration Time	Filter	Rejected Noise and Notes
100 ms	1.67 ms	Rectangular	600 Hz and its integer multiples*
200 ms	16.67 ms		60 Hz and its integer multiples
	20 ms		50 Hz and its integer multiples
	Auto		Automatically detects the power supply frequency and set 16.67 or 20 ms
500 ms	36.67 ms	Trapezoidal	50 Hz or 60 Hz and their integer multiples
1 s	100 ms	Rectangular	10 Hz and its integer multiples
2, 5, 10, 20, 30, 60 s	200 ms	Cos	Fc = 5-Hz low-pass filter

* Since the power supply frequency noise is not rejected, the measured values may fluctuate. In such cases, set the measurement interval to 200 ms or higher.

Measurement Synchronization

The module is equipped with a single A/D converter, and measurement is made sequentially. Therefore, measurements of each channel are not synchronized.

Common Mode Voltage

For -B12 or -B35

The common mode voltage between channels in a single module when applied continuously is 30 VACrms, or 250 VACrms between input and ground.

For -NDI

The common mode voltage between channels in a single module when applied continuously is 30 VACrms, and 30 VACrms between input and ground (shell is non-isolated).

Initial Balancing (Initial Unbalance Value Adjustment)

When configuring a bridge circuit with a strain gauge, the bridge circuit will not necessarily be balanced even if the strain of the circuit under test is zero due to the slight deviation in resistance of the strain gauge, and the measured value may not be zero (the value in such cases is called the *initial unbalanced value*.)

Therefore, when taking measurements you must first balance the bridge and, if the strain is zero, obtain a measured value of zero. This is called *initial balancing* (setting the initial unbalanced value to zero).

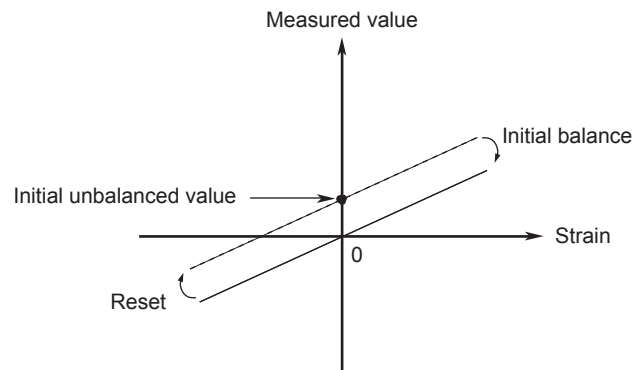

With the MX100, initial balancing is performed in the $\pm 10000 \mu$ strain range.

Initial balance: The value when the command is executed is taken as the initial unbalanced value, and the measured value is set to zero.

Reset: The value set during initial balancing is reset to zero. The initial unbalanced value is used as-is for the measured value.

Note

If the measuring range is changed, the initial balancing is reset.
After a range change, you must redo initial balancing.

Scaling Settings When Using a Strain Gauge Type Sensor

The following is an explanation of scaling settings used when measuring physical quantities such as load and length with a strain gauge type sensor.

The basic relational expression is as follows.

$$1 \text{ mV/V} = 2000 \text{ } \mu\text{strain (Equation 1)}$$

Two examples are given below: 1) when rated input and output are listed in the user's manual of the strain gauge type sensor, and 2) when listed with the calibration coefficient. (Hereinafter, "μstrain" will be expressed as "μStr.")

When Rated Input and Rated Output Are Given

A specific example is given below.

- Rated input 200 N (set to Y)
- Rated output 0.985 mV/V (set to K)

In this case, these figures indicate that if a 200 N load is applied, 0.985 mV/V is output.

From the relationship in equation 1, if 200 N is applied, an output of $0.985 \text{ mV/V} = 0.985 \times 2000 = 1970 \text{ } \mu\text{Str}$ is attained.

In other words, for each 1 N, $1970 \text{ } \mu\text{Str} / 200 \text{ N} = 9.85 \text{ } \mu\text{Str/N}$ is output. Therefore, the scaling settings are entered as follows.

When Measuring at 50-150 N

Scale minimum: 50 (set to Smin)

Scale maximum: 150 (units: N) (set to Smax)

therefore,

$$\text{Span minimum: } 50 \times 9.85 \text{ } \mu\text{Str/N} = 492.5 \text{ } \mu\text{Str}$$

$$\text{Span maximum: } 150 \times 9.85 = 1477.5 \text{ } \mu\text{Str}$$

can be set.

Thus, the measuring range is 2000 μStr.

Generally, the range is as follows.

Using the symbols that have appeared in the explanation thus far, after setting the scale maximum and minimum, the values are as follows.

$$\text{Span minimum} = [(K(\text{mV/V}) \times 2000) / Y(\text{unit})] \times \text{Smin} ([\mu]\text{Str})$$

$$\text{Span maximum} = [(K(\text{mV/V}) \times 2000) / Y(\text{unit})] \times \text{Smax} ([\mu]\text{Str})$$

1.7 Functions of the 4-CH, Medium-Speed Strain Input Module (-B12, -B35, and -NDI)

When Listed at the Calibration Coefficient

An example is given with a displacement gauge.

- Rated input: 20 mm
- Calibration coefficient: 0.003998 mm / (1 μ V/V)

Basically, if you can convert the calibration coefficient to the rated output mentioned in "When Rated Input and Rated Output Are Listed," the following is a calculation following the explanation in "When Rated Input and Rated Output Are Listed."

Using equation 1,

$$1 \mu\text{V/V} = 0.001 \mu\text{V/V} = 0.001 \times 2000 \mu\text{Str} = 2 \mu\text{Str}$$

therefore the rated output with this sensor when 20 mm is input would be

$$20 \text{ mm} \div [0.003998 \text{ mm}/2 [\mu]\text{Str}] = 10005 \mu\text{Str}$$

In other words, for each 1 mm, an output of

$$10005 \mu\text{Str} / 20 \text{ mm} = 500.25 [\mu]\text{Str}/\text{mm}$$

can be obtained.

Thereafter in the same manner, if you wish to measure with a scale of 2 mm to 15 mm, the settings are:

Scale minimum: 2

Scale maximum: 15 (units: mm)

therefore,

$$\text{Span minimum: } 2 \times 500.25 \mu\text{Str}/\text{mm} = 1000.5 \mu\text{Str}$$

$$\text{Span maximum: } 15 \times 500.25 \mu\text{Str}/\text{mm} = 7503.75 \mu\text{Str}$$

would be appropriate settings.

The measuring range becomes 20000 μ Str, making the resolution on the MX100 1 mStr, therefore we can round as follows.

Span minimum: 1001 μ Str

Span maximum: 7504 μ Str

Compensation When the Gauge Factor Differs

If the gauge factor of the gauge being used differs from 2.00, it can be compensated using the following method.

The relationship between the true strain (s) and the measured strain (si)

is:

$$\varepsilon_i = 2.00/K_s \times \varepsilon_s$$

Ks: Gauge factor of the gauge used

Given this, set the following using the scaling function.

Measurement Span		Scale	
Minimum value	Maximum value	Minimum value	Maximum value
X	Y	$2.00/K_s \times X$	$2.00/K_s \times Y$

Ex.: for a gauge factor of 2.1,

Measurement Span		Scale	
Minimum value	Maximum value	Minimum value	Maximum value
-1000.0	2000.0	-952.4	1904.8

1.8 Functions of the 10-CH, High-Speed Digital Input Module (-D05, -D24)

The -D05 module is equipped with ten inputs and measures non-voltage contact, open collector, and 5-V logic inputs at a minimum measurement interval of 10 ms.

The -D24 module is equipped with ten inputs and measures 24 V logic inputs at a minimum measurement interval of 10 ms.

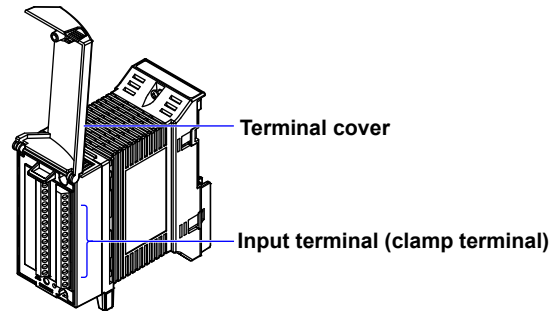

Measurement Interval

You can select a measurement interval of 10 ms, 50 ms, 100 ms, 200 ms, 500 ms, 1 s, 2 s, 5 s, 10 s, 20 s, 30 s, or 60 s.

Filters

The module detects ON/OFF as shown below to prevent receiving chattering effects. If the measurement interval is set at a value greater than four times the chattering period, measurement is possible in which chattering effects are avoided.

- Measurement interval of 5 s or less: Use the wider of the ON/OFF widths of the detection period (approximately 75 to 90% of the measurement interval)

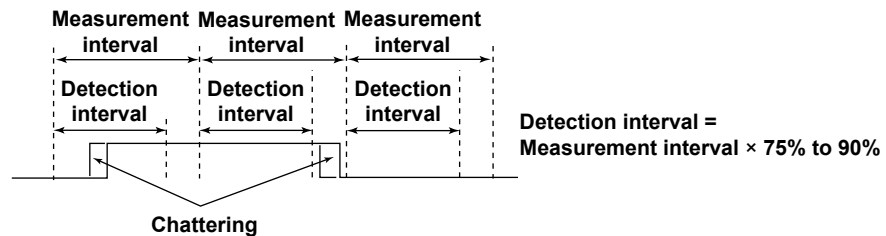

- Measurement interval of 5 s or more: Use the wider of the ON/OFF width of approximately 4.5 s

1.9 Functions of the 8-CH, Medium-Speed Analog Output Module

This module is equipped with 8 outputs that can output voltage or current. An external power source (24 V) is required for current output. For voltage output only, an external power source is not required.

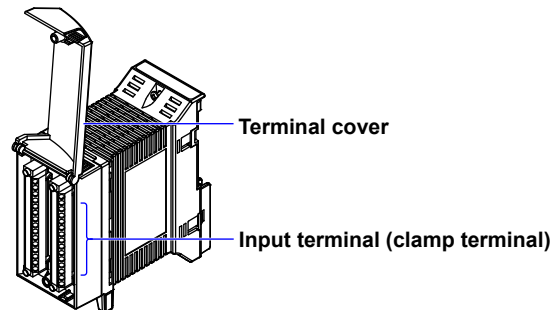

Output Type

Transmission output: Outputs a voltage or current corresponding to the measured results of the input channel specified on the same unit.

User output: The specified value is output based on the value sent from the PC software. Transmission output of computation channel data or of data from separate units is available.

Output Range

Voltage: -10.000 V to 10.000 V

Current: 0.000 mA to 20.000 mA

Output Update Interval

The output is updated every 100 ms (minimum). It is not synchronized to the measurement interval.

Operation When Errors Occur upon Startup

See section 1.11.

Output Operation During Calibration

Calibration Status	Output Status
Channels being calibrated	User output (output of calibration value)
Calibrated channels	Holds the last calibration user output value*
Non-calibrated channels	Holds the output value (holds the last output value during steady operation (see section 1.11))

* Holds the last calibration user output value until the next output update.

1.10 Functions of the 8-CH, Medium-Speed PWM Output Module

This module is equipped with eight outputs that can output pulse wave duty. A duty pulse waveform is output according to the specified pulse interval. A pulse interval can be set for each channel.

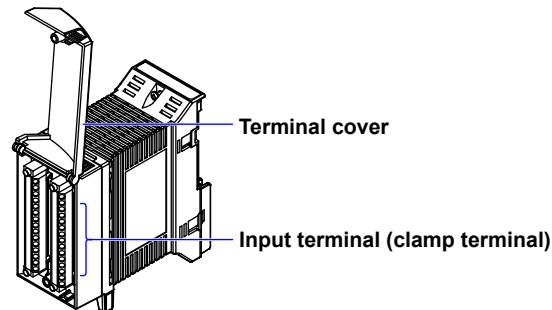

Output Type

Transmission output: Outputs a duty pulse waveform corresponding to the measurement computation results of the input channel specified on the same unit.

User output: The specified value is output based on the data sent from the PC software. Transmission output of computation channel data or of data from separate units is possible.

Output Waveform

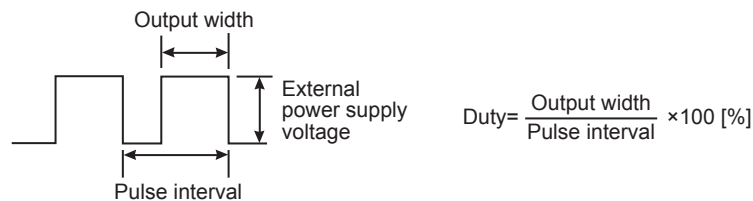

Pulse Interval

1 ms to 300 s (can be set channel by channel)

However,

1 ms interval setting rng: 1 ms to 30.000 s Can be set in units of 1 ms

10 ms interval setting rng: 10 ms to 300.00 s Can be set in units of 10 ms

Output Update Interval

The output is updated every 100 ms (minimum). It is not synchronized to the measurement interval.

Output Range

0.000% to 100.000%

Operation When Errors Occur upon Startup

See section 1.11.

1.11 Operation of the 8-CH Medium-Speed Analog Output Module and the 8-CH Medium Speed PWM Output Module

This section provides an explanation of the output operation of the analog output and PWM output modules.

Output Selection When Errors Occur upon Startup

- Hold the previous value: Holds the last output value.
- Output the preset value: Outputs an arbitrarily specified output value.

Output Status

The voltage, current (analog output module), or pulse wave duty (PWM output module) is output given the following output conditions.

- Transmission output: Outputs an analog or PWM corresponding to the measured results of the input channel specified on the same unit.
The input modules that can be specified are all input modules (excludes output modules).
- User output: When a command is received from a PC software application (MX100 Standard Software, MXLOGGER, or the MX100/DARWIN API), analog or PWM output is performed according to the received value.

After the power is turned ON and communications become available, "User Output" is enabled. For transmission output within a unit, the output value is updated after measurement begins.

Output on Disabled Channels

Types of Disabled Channels	Output
Channels disabled through setting changes	Holds the last output value when channels were active
Channels disabled upon startup	Output according to startup settings

The timing at which setting changes applied to the output module become active is as follows.
(Ex. When changing settings from transmission output within a unit to user output, the last value of transmission output within a unit is held until the user output request is generated.)

Output Operation per Settings and Setting Changes

Status at Power ON and Output Operation

Status When Power Is Turned ON	Output Operation	
When the output setting is disabled	Operation upon startup	
For transmission output within units, referenced input channels disabled*	Before meas. start	Operation upon startup
	Measurement start	Operation upon errors
Transmission output within units	Before meas. start	Operation upon startup
	Measurement start	Transmission output
Transmission output between units (User output)	Before meas. start	Operation upon startup
	Measurement start	User output
Manual output (User output)	No output request	Operation upon startup
	Output requested	User output
Pattern output (User output)	Before pattern output starts	Operation upon startup
	Pattern output starts	User output

* Monitor "Off" on the PC software, and "Skip" on the MX100/DARWIN API.

1.11 Operation of the 8-CH Medium-Speed Analog Output Module and the 8-CH Medium Speed PWM Output Module

Output Operation per Setting Changes (Common)

Setting Changes (Contents)	Output Operation	
Changes to settings for op.	Hold prev. val. → preset val.	Outputs a preset value the next time upon startup the power is turned ON
	Preset val. → hold prev. val.	The last output value from the previous operation is held for the next time the power is turned ON (outputs the output value active when the power was last turned OFF during the previous session)
Changes to settings for op.	Hold prev. val. → preset val.	Outputs a preset value the next time when error occurs an error occurs
	Preset val → hold prev. val.	Holds the last output value active before an error occurs even when the next error occurs.
Changes to the preset value setting*	No change (as above)	
Output ch setting changed from Enabled → Disabled	Holds the output val. (last output val.)	

* Changes are also applied to inactive channels.

Output Operation through Setting Changes (Individually by Output Setting)

Output Setting	Setting Changes (Contents)	Output Operation	
Trans. output within units	Range setting chng.	AO: V ↔ mA	Output value held (until next output event)
		PWM: 1 ms ↔ 10 ms or interval	
	Op. setting chng.	Trans. within units → Trans. between units	
		Trans. within units → manual output Trans. within units → pattern output	
Trans. output between units (user output)	Range setting chng.	AO: V ↔ mA	Output value held (until next output event)
		PWM: 1 ms ↔ 10 ms or interval	
	Op. setting chng.	Trans. between units → trans. within units	
		Trans. between units → manual output Trans. between units → pattern output	
Manual output (user output)	Range setting chng.	AO: V ↔ mA	Output value held (until next output event)
		PWM: 1 ms ↔ 10 ms or interval	
	Op. setting chng.	Manual output → trans. within units	
		Manual output → trans. between units	
Manual output → pattern output			
Span setting changes			
Pattern output (user output)	Range setting chng.	AO: V ↔ mA	Output value held (until next output event)
		PWM: 1 ms ↔ 10 ms or interval	
	Op. setting changes	Pattern output → trans. within units	
		Pattern output → trans. between units	
Pattern output → manual output			
Span setting changes			

If the PWM output module range setting is changed, the output value is not saved (the interval changes)

Steady Output Operation

Output Operation While Communication Is Connected

Communication Connection Status	Output Operation
Comm. connects (initial connection after power ON)	Operation upon startup
Comm. connects (disconnected and restored for the 2nd or more time)	Holds the output value (last output value)
Communication disconnected normally	Holds the output value (last output value)

Output Operation according to the Measurement Status and Transmission Output Status

Transmission output in the table is ON when Transmission output is selected in the Action menu of the MX100 Standard Software, or when DAQMXTRANSMIT_RUN is executed in the MX100/DARWIN API. Transmission output in the table is OFF when Transmission output is cleared in the Action menu of the MX100 Standard Software, or when DAQMXTRANSMIT_STOP is executed in the MX100/DARWIN API.

Output Setting	Status	Output Operation	
Trans. output within units	Meas stop → meas. start	Starts trans. output/holds within units output value (depends on trans. output execution on/off) on: transmission output starts off: holds output value	
	Measuring → meas. stop	Holds output value (last output value)	
	Meas stopping	Trans. output exec. on* → off* Trans. output exec on → off	Holds output val. (no chng.) Holds output val. (no chng.)
	Measuring	Trans. output exec off → on Trans. output exec on → off	Starts trans. output Holds output val. (last val.)
Trans. output between units (user output)	Meas stop → meas start	Starts user output or holds output value (depends on trans output exec. on/off status) on: transmission output starts off: output value held	
	Measuring → meas stop	Holds output value (last output value)	
	Meas stopping	Trans. output exec off → on Trans. output exec on → off	Holds output val. (no chng.) Holds output val. (no chng.)
	Measuring	Trans. output exec off → on Trans. output exec on → off	User output Holds output val. (last output value)
Manual output (user output)	Meas stop → meas start	No effect	
	Measuring → meas stop	No effect	
	Meas stopping	Trans. output exec off → on Trans. output exec on → off	No effect No effect
	Measuring	Trans. output exec off → on Trans. output exec on → off	No effect No effect
Pattern output (user output)	Meas stop → meas start	No effect	
	Measuring → meas stop	No effect	
	Meas stopping	Trans. output exec off → on Trans. output exec on → off	No effect No effect
	Measuring	Trans. output exec off → on Trans. output exec on → off	No effect No effect

* on: enabled off: disabled

Transmission output execute enabled: when "Transmit" under the Action menu of the PC software is selected

Transmission output execute disabled: when "Transmit" under the Action menu of the PC software is not selected

Output When Abnormal, or after Recovery from Abnormality

Output Operation during Abnormality (by Module)

Abnormal Module	Abnrml Display	Abnormal Status	Output Operation
Main Module	b[SQR] [*]	System error	Operation upon startup
	bF	Dip switches	
	F0	ROM error	
	F1	SRAM error	Operation upon startup
	F2	EEPROM error	
	F3	Battery error	
	F4	Ethernet error	
	P[SQR] [*]	CF card related error	No effect (normal operation)
	None	Communication timeout error	Transmission within units: no effect (normal operation) Transmission between units/manual output/pattern output: operation when error generated
	C1	Comm multiple connect error	No effect (normal operation per the previously connected device)
Output Modules	E0		Range information error Operation upon startup or when output value uncertain
	E1	Calibration value error	
	E2	Error during calibration	Internal communication error occurs, resulting in an error recovery event. If the error recovery time is 10 s or more, output is performed per the operation upon error occurrence, and then output is executed per the operation upon startup.
	E3	Error in writing the calibration value.	
	E4	Unusable modules	Operation upon startup or when output value uncertain
Input Modules	E0	Range information error	Operation upon errors occurrence (except for transmission within
	E1	Calibration value error	units, since the transmission
	E4	Unusable modules	source input channel is illegal)
	E5	Initial balance error	No effect (\pm Over is likely)

* [SQR] is a placeholder for the number corresponding to the error.

Output Operation during Abnormality (by Output Setting)

Output Setting	Abnormal Status	Output Operation
Trans. output within units	Referenced input channels are +Over	Outputs a value +5% of the specified span of the output channel ^{*2}
	Referenced input channels are –Over	Outputs a value –5% of the specified span of the output channel ^{*2}
	Referenced input channel is illegal	Operation upon errors (input modules are removed)
	Referenced input channel is disable ^{*3}	
	Referenced input channel is Invalid (math error in difference computation)	
	Communication timeout	No effect
	Internal communication error	Output value held (immediately after internal comm error occurs, the output value is held, but there is a recovery operation ^{*1})
CPU abnormality	Operation upon errors	
Trans. output between units (user output)	Referenced input channels are +Over	Outputs a value +5% of the specified span of the output channel (calculated with MXSTANDARD, MXLOGGER, or the API)
	Referenced input channels are –Over	Outputs a value –5% of the specified span of the output channel (calculated with MXSTANDARD, MXLOGGER, or the API)
	Referenced input channel is illegal (input modules are removed)	Operation upon errors (with MXSTANDARD, MXLOGGER, or the API)
	Referenced input channel is disable ^{*3}	MXLOGGER, or the API)
	Referenced input channel is Invalid (math error occurs)	
	Communication timeout	Operation upon errors
	Internal communication error	Output value held (immediately after internal comm error occurs, the output value is held, but there is a recovery operation ^{*1})
CPU abnormality	Operation upon errors	
Manual output (user output)	Communication timeout	Operation upon errors
	Internal communication error	Output value held (after internal comm error occurs, the output value is held, but there is a recovery operation ^{*1})
	CPU abnormality	Operation upon errors
Pattern output (user output)	Communication timeout	Operation upon errors
	Internal communication error	Output value held (immediately after internal comm error occurs, the output value is held, but there is a recovery operation ^{*1})
	CPU abnormality	Operation upon errors

*1 See “Output Operation after Recovery from Abnormality” on the next page.

*2 However, only within the range that can be output.

Ex.: If the span for PWM is set to 0-100%, +Over is +100% and –Over is 0%.

*3 Invalid with the MX100 Standard Software. With the API for MX100 and DARWIN, it is “Skip.”

1.11 Operation of the 8-CH Medium-Speed Analog Output Module and the 8-CH Medium Speed PWM Output Module

Output Operation after Recovery from Abnormality (by Output Setting)

Output Setting	Abnormality Recovery	Output Operation
Trans. output within units	Referenced input module recovers (removed input modules are inserted)	Operation upon errors → transmission output
	Referenced input channel changed from Skip to measurement range	
	Referenced input channel is Invalid Recovers to normal from (math error in difference computation)	
	Recover after communication timeout	No effect
	Recover after internal comm error	If the error recovery time is 10 s or more; operation upon error occurrence → operation upon startup → transmission output If the error recovery time is within 10 s; operation upon startup → transmission output
	CPU abnormality (does not recover)	Operation upon errors
Trans. output between units (user output)	Referenced input module recovers (removed input modules are inserted)	Operation upon errors (per PC software → user output ^{*1})
	Referenced input channel changed from Skip to measurement range. ^{*2}	
	Referenced channel is invalid; recovers to normal value from (math error).	
	Recover after communication timeout	Operation upon errors → user output ^{*1}
	Recover after internal comm error	If the error recovery time is 10 s or more; operation upon error occurrence → operation upon startup → user output ^{*1} If the error recovery time is within 10 s, Operation upon startup → user output ^{*1}
	CPU abnormality (does not recover)	Operation upon errors
Manual output (user output)	Recover after communication timeout.	Operation upon errors → user output ^{*1}
	Recover after internal comm error	If the error recovery time is 10 s or more, Operation upon errors → operation upon startup → user output ^{*1} If the error recovery time is within 10 s, Operation upon startup → user output ^{*1}
	CPU abnormality (does not recover)	Operation upon errors
Pattern output (user output)	Recover after communication timeout	Operation upon errors → user output ^{*1}
	Recover after internal comm error	If the error recovery time is 10 s or more; operation error occurrence → operation upon startup → user output ^{*1} If the error recovery time is within 10 s, Operation upon startup → user output ^{*1}
	CPU abnormality (does not recover)	Operation upon errors

*1 Executes the user output from the PC software after recovery from errors.

*2 Invalid with the MX100 Standard Software. With the API for MX100 and DARWIN, it is "Skip."

1.12 Functions of the 10-CH, Medium-Speed Digital Output Module

This module outputs ten contact signals based on the alarm output settings and output settings on the PC software.

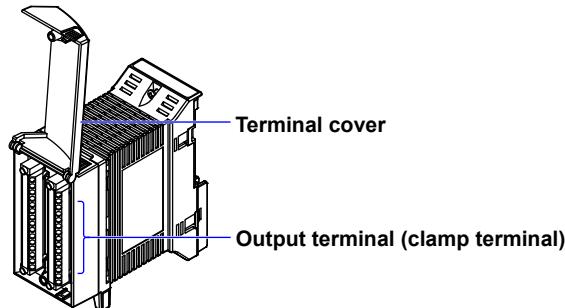

Output Type

The MX100 has the following types (output factors) are available.

Type	Description	Relay Action	Output Hold Behavior
Alarm	Alarm output of measurement / computation channels	Energize or deenergize selectable	Hold ^{*2} or non-hold selectable
Manual	Manual DO operation using the software	Energize or deenergize selectable	
Fail	When a failure occurs in the CPU of the MX100 main module	Normal: Energized Failure: Deenergized	
Error	Output when an error ^{*1} is detected in the MX100	Energize or deenergize selectable	Hold ^{*2} or non-hold selectable

*1 Below are the errors that can occur in the MX100.

- A data output request timeout (60 s) occurs while recording data. (except when the /DS option functions are enabled)
- An input module detected at power-on that is able to make measurements is removed.
- A module breaks down.
- An unidentifiable module is attached.

*2 Holds the output until the PC software issues the output release command (relay ACK).

Output Update Interval

The output is updated every 100 ms (minimum). It is not synchronized to the measurement interval.

Relay Action and Hold Behavior

You can select whether to energize or de-energize the output relay when outputting contact signals on the PC software. You can also select whether the output relay is turned OFF (non-hold) or kept ON (hold) until an output release command is received.

• When set to non-hold

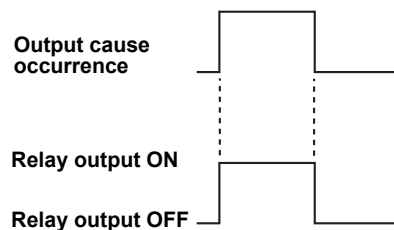

• When set to hold

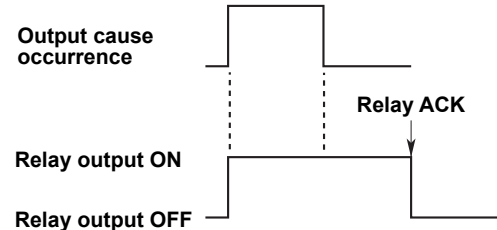

2.1 Handling Precautions

This section describes the precautions to be taken when using the MX100. Please read this section carefully before use.

- If you are using this instrument for the first time, make sure to thoroughly read the safety precautions given on pages ii and iii.
- Do not remove the case.
For internal inspection or adjustment, contact your nearest YOKOGAWA dealer.
- Do not place objects on top of the instrument.
Never place other instruments or objects containing water on top of the instrument. Doing so can lead to malfunction.
- Take Proper Care When Carrying the Instrument
First, turn off the DUT and the MX100 and remove all cables including measurement wires and communication cables. Then, remove the power cord from the outlet.
- To prevent internal overheating, do not obstruct the vent holes of the module.
- This instrument uses many plastic parts. When cleaning, wipe using a dry soft cloth. Do not clean with benzine, thinner, or other chemicals, and do not use detergents. Doing so can cause discoloring, deformation, or damage.
- Do not bring charged objects near the signal terminals. Doing so can lead to malfunction.
- Do not pour volatile agents on the MX100 or leave it in contact with rubber or PVC products for an extended time. Doing so can lead to malfunction.
- Do not apply shock to the instrument.
- When not in use, make sure to turn OFF the power.
- If there are any symptoms of trouble such as smoke, strange odors, or strange sounds coming from the instrument, immediately turn OFF the power and stop the power supply. Contact your dealer immediately.
- Do not damage the power cord.
Nothing should be placed on top of the power cord. The power cord should also be kept away from any heat sources. When unplugging the power cord from the outlet, never pull by the cord itself. Always hold and pull by the plug. If the cord is damaged, contact your dealer for replacement. Refer to “Checking the Contents of the Package” in the MX100 Data Acquisition Unit Operation Guide (IM MX100-02E) for the part number of the appropriate power cord when placing an order.

2.2 Installation

Installation Location

Install the instrument indoors in the following locations.

- **Where the temperature is between 0 to 50°C.**
Where the relative humidity is between 20 and 80% RH for 0 to 40°C and 10 and 50% RH for 40 to 50°C. However, no condensation should be present.

Note

Condensation may occur if the instrument is moved to another place where the ambient temperature is higher, or if the temperature changes rapidly. In addition, measurement errors will occur when using thermocouple input. In this case, let the instrument adjust to the new environment for at least an hour before using the instrument.

- **Where the operating altitude is 2000 m or less.**
- **In a well-ventilated location**
Install the instrument in a well-ventilated location to prevent the temperature inside the instrument from rising.
- **Where mechanical vibration is small**
Select an installation location with a small amount of mechanical vibration (if any).
- **In a horizontal location**
Install the instrument on a flat, even surface.

Do not install the instrument in the following places.

- **In dangerous locations where flammable liquid, vapor, or dust is present**
- **In direct sunlight or near heat appliances**
Select a location with the smallest temperature fluctuation from room temperature (23 °C) as possible. Placing the instrument in direct sunlight or near heat appliances can cause adverse effects.
- **Where an excessive amount of soot, steam, humidity, dust, or corrosive gas is present**
Soot, steam, humidity, dust, and corrosive gas can cause adverse effects on the instrument. Avoid installing the instrument in an environment with a high level of such elements.
- **Near magnetic field sources**
Install the instrument in a location where the magnetic field is 400 A/m or less. Avoid bringing instruments that produce magnetic fields or magnets near the instrument. Using the instrument near a strong magnetic field source can cause measurement errors.

Installation Procedure

CAUTION

When mounting the instrument on DIN rails, prevent the instrument from falling by securing the DIN rails using a metal plate of 2 mm or more in thickness, fastened with at least three screws.

The MX100 can be used on a desktop, on a floor, in a rack mount, or in a panel mount. In all cases, be sure to install the instrument in a vertical position.

Use on a Desktop or a Floor

Each module has feet that can be attached to the base plate allowing them to be placed vertically. For the procedure for attaching the modules, see the next page.

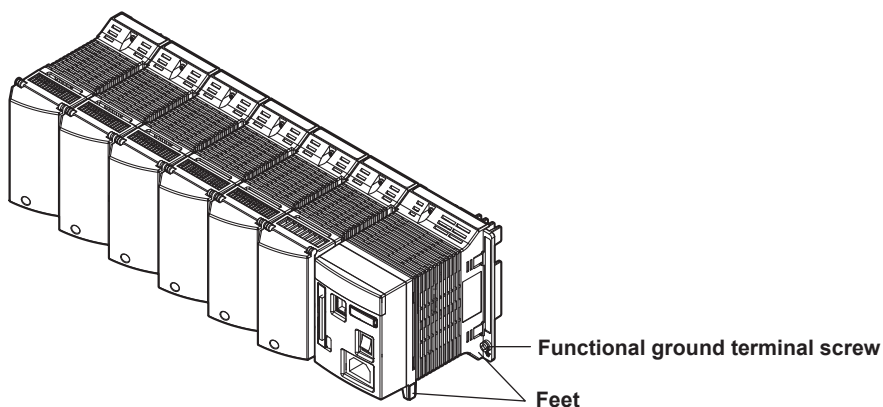

Attachment to a DIN Rail

As shown in the figure below, you can rack-mount or panel-mount the MX100 by attaching a DIN rail mount bracket to the base plate.

- Attachment of the DIN rail mount bracket to the base plate

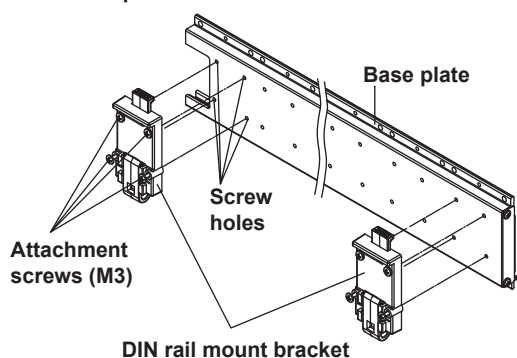

- Attachment of the base plate to the DIN rail

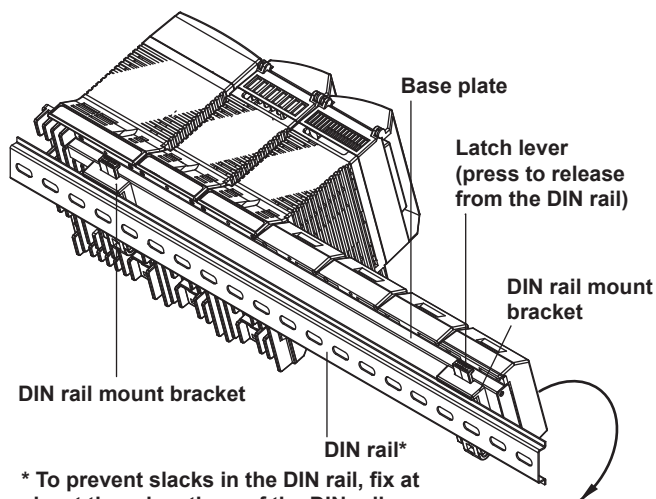

- Dimensions when mounted on a DIN rail

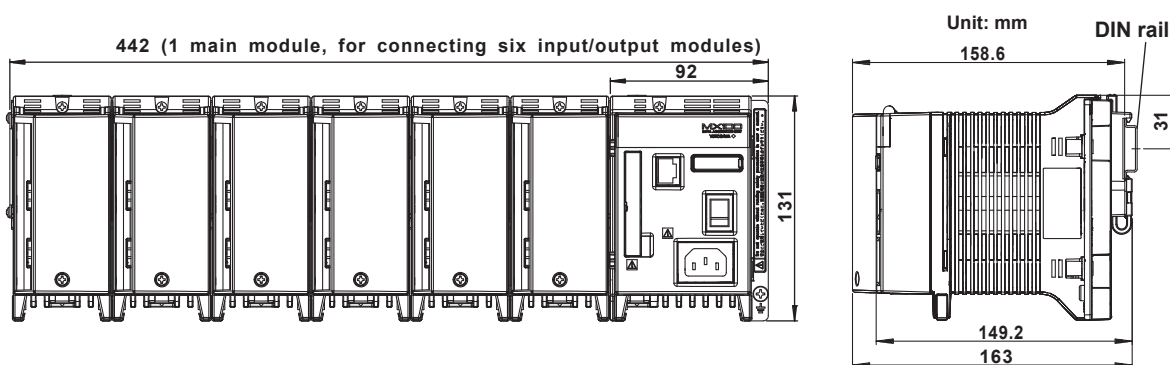

2.3 Attaching the Modules



WARNING

To prevent electric shock and instrument breakdown, do not connect the power supply to the main module when attaching modules.

Attachment Procedure

1. Check that the power supply is not connected to the main module.
2. Align the connector on the rear panel of the module to the module connector on the base plate, and insert the connector.
Attach the main module to the right-most position on the base plate.
When the connectors are correctly connected, the guide pin on the rear panel of the module is inserted into the guide hole on the base plate. In addition, the module is secured to the base plate with the latch lever locking in place at the bottom section of the base plate.
3. Fasten the top of the module with the attachment screws (M3).

To remove the module, loosen the attachment screw, pull down on the latch lever on the rear panel of the module, and pull the module straight from the base plate.

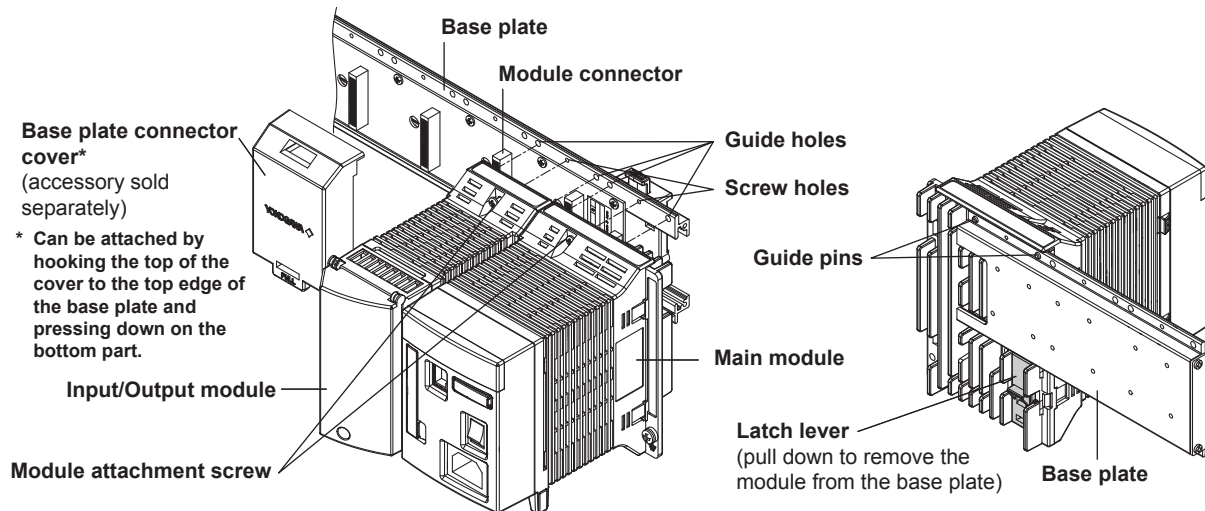

CAUTION

When attaching the main module (conventional model) to the base plate, first remove the two screws from the base plate and remove the BRACKET, then attach the main module (conventional model) to the base plate.

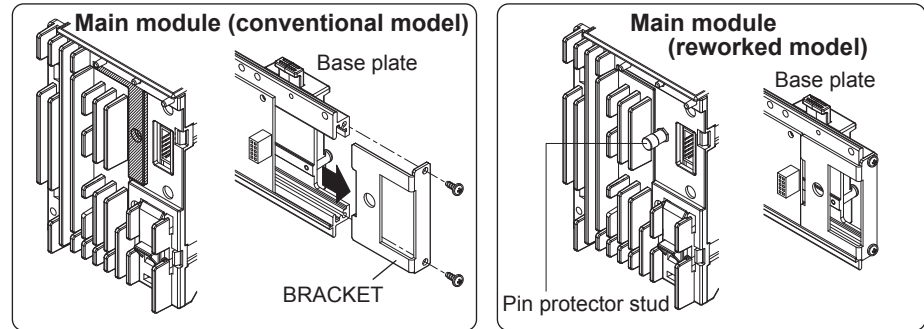

Attachment Positions and Channel Numbers

The figure below shows how the channel numbers are identified on the PC.

Representation of channel numbers:

Channel numbers in a unit (001 to 060)
Unit number (00 to 19)**1

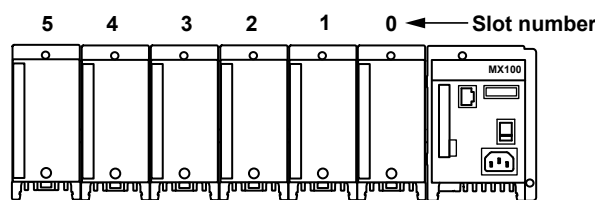

*1 When connecting to the module using the MX100 Standard Software, the number is fixed to 00.

041 to 050 021 to 030 001 to 010
051 to 060 031 to 040 011 to 020

Channel number in the unit**2
*2 The last one digit on a 4-channel module is 1 to 4.
The last one digit on a 6-channel module is 1 to 6.
The last one digit on a 8-channel module is 1 to 8.

CAUTION

The 30-CH, Medium-Speed DCV/TC/DI Input Module takes up three modules worth of space when attaching to the base plate. If attached incorrectly, damage or malfunction can result.

2.4 Connecting the Signal Wires

Terminal Arrangement Markings on the Terminal Cover

A character indicating the terminal function and a terminal symbol indicating the type of signal to be input/output at each terminal are written on the back of the terminal cover of each I/O module. For information on the wiring of each terminal signal, see “Connecting the Signal Wires” (this section). The 4-CH, Medium-Speed Strain Input Module (-NDI) has no terminal cover.

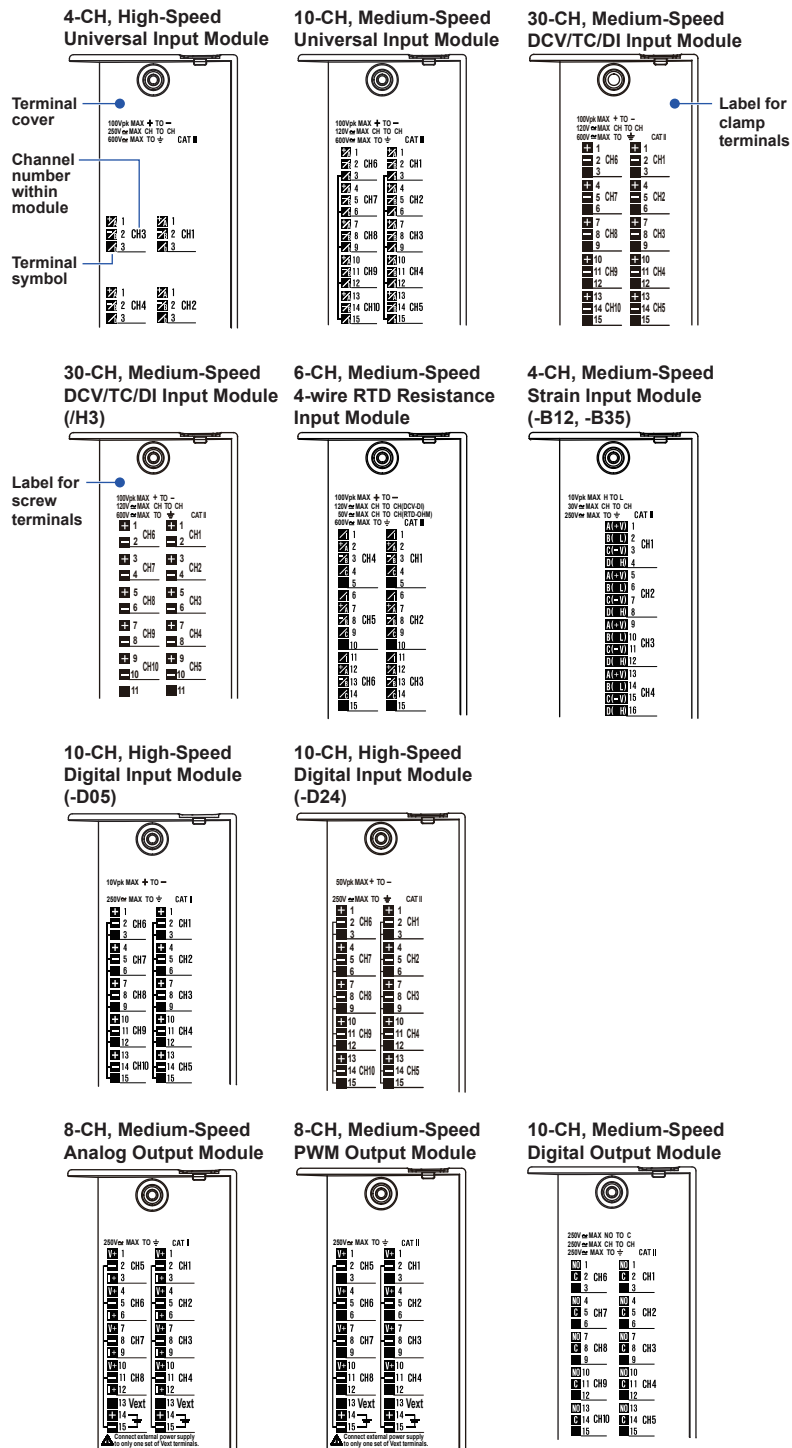

Attaching and Removing the Terminal Block

The terminals of the input/output modules in the figure below can be removed. The terminal cover can be removed by pressing backward with the cover lifted up.

4-CH, High-Speed Universal Input Module

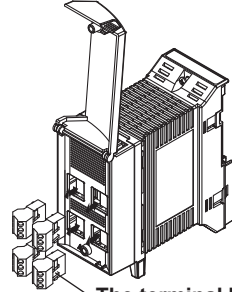

The terminal block can be attached and detached.

4-CH, Medium-Speed Strain Input Module (-B12, -B35)

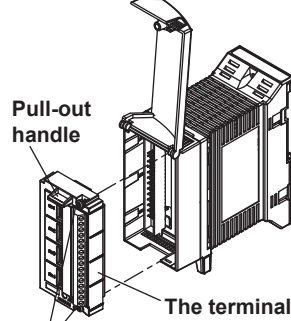

The terminal plate can be attached and detached.

Attachment screw
(Loosen before removing the terminal plate.)

**10-CH, Medium-Speed Universal Input Module/
6-CH, Medium-Speed Four-wire RTD Resistance Input Module/
10-CH, High-Speed Digital Input Module**

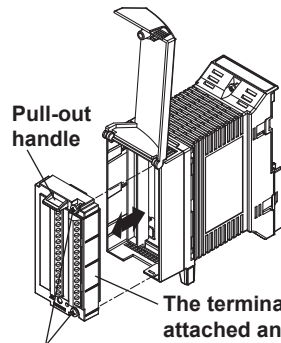

The terminal plate can be attached and detached.

Attachment screw
(Loosen before removing the terminal plate.)

**8-CH, Medium-Speed Analog Output Module/
8-CH, Medium-Speed PWM Output Module/
10-CH, Medium-Speed Digital Output Module**

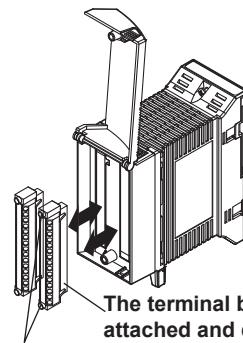

The terminal block can be attached and detached.

Attachment screw
(Loosen before removing the terminal block.)

Attaching Plates with Screw Terminals and Plates with Clamped Terminals for Current

You can attach a plate with screw terminals (sold separately, M3 screws) to the 10-CH, Medium-Speed Universal Input Module and the 10-CH, High-Speed Digital Input Module. You can also attach a plate with clamped terminals for current (sold separately) to the 10-CH, Medium-Speed Universal Input Module.

The plate is attached and removed in the same manner as terminal blocks. Note that the terminal arrangement of the plate with screw terminals differs from that of the plate with clamped terminals. The terminal arrangement is displayed on the back of the terminal cover in the same package. Replace it along with the plate.

For handling of the plate with screw terminals, see “MX100/MW100 Handling of the Plate with Screw Terminals” (IM MX100-77E), and for the plate with clamped terminals for current, see “MX100/MW100 Setting Up the Plate with Clamp Terminals for Current” (IM MX100-78E).

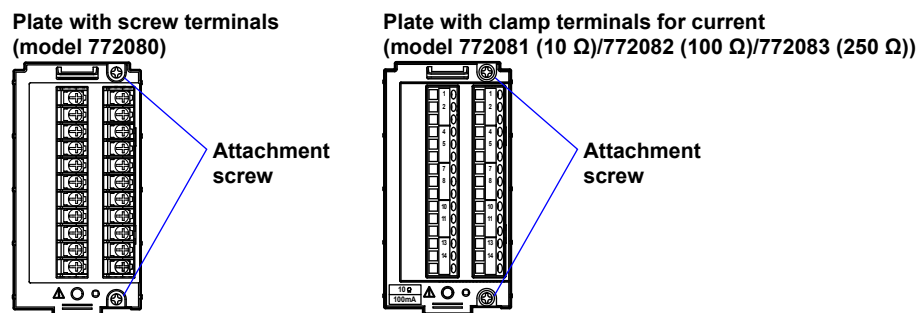

Screw Terminal Block

The 10-CH, Medium-Speed Universal Input modules and 10-CH, High-Speed Digital Input modules allow you to remove the terminal plate and connect a 10-channel screw terminal block (M4 screws, sold separately) that can be attached to a DIN rail (see the figure below).

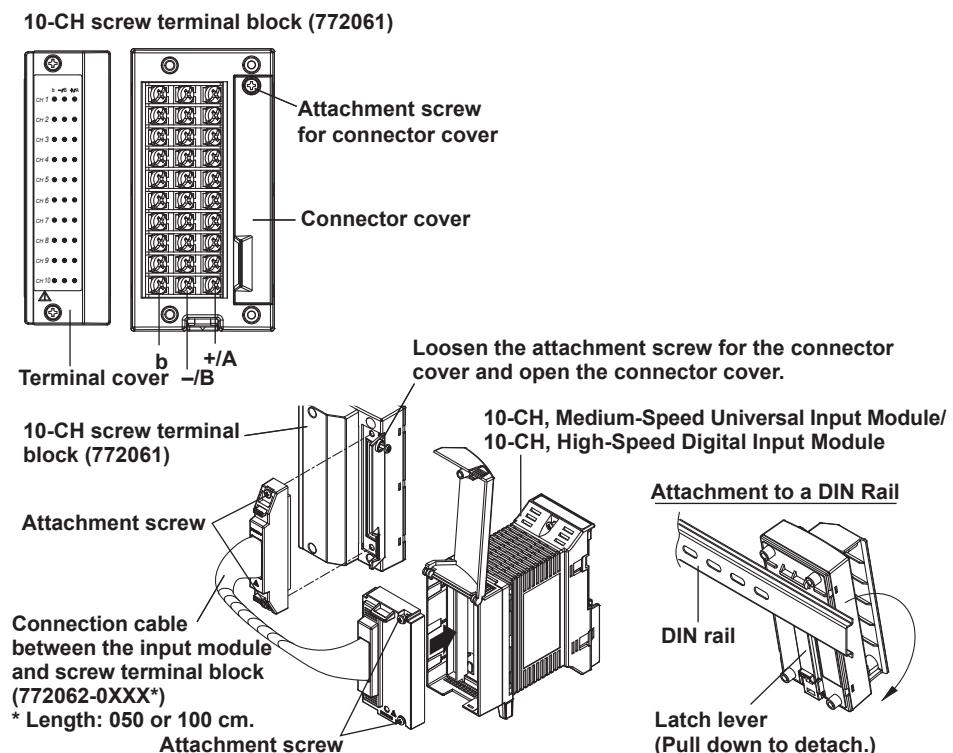

General Precautions When Wiring the Input/Output Signal Wires



WARNING

- To prevent the possibility of electric shock when wiring, confirm that the power supply source and signal source are turned OFF. After making the connections, secure the terminal cover and do not touch the terminals with your hands.
- For signal wires on which voltage exceeding 30 VAC/60 VDC is applied relative to the ground potential or between signals, use reinforced (double) insulation wires. For all other signal wires, use basic insulation wires. For the withstand voltage of insulation wires, see the table below.

Applied Voltage (Vrms or VDC)	Basic Insulation	Double (Reinforced) Insulation
30 (60 VDC)-100	620 V rms	1000 V rms
101-150	840 V rms	1400 V rms
151-300	1390 V rms	2300 V rms
301-600	2210 V rms	3700 V rms

- To avoid electric shock when removing the terminal block and terminal plate for wiring, be sure to attach the terminal block and terminal plate to the input/output module before inputting or outputting signals. Electric shock or fire can result if signals are applied to the terminals when the terminal block is removed from the input/output modules.
- When wiring to screw terminals, use insulation coated crimp-on lugs on the terminals (4 mm screws on the screw terminal block, and 3 mm screws on the screw terminals and screw terminal plate). Use round crimp-on lugs that do not come out when loose.
- To prevent fire, use signal wires with a temperature rating in the table below or higher.

Module Type	Temp. Rating
Screw terminal block	75°C
Universal input module, DCV/TC/DI input module, four-wire RTD resistance input module, strain input module, digital input module, and digital output module	80°C
Analog output module, PWM output module	85°C



CAUTION

- If a large pulling force is applied to the input/output signal wires connected to the MX100, the terminal or signal wire may break. To prevent this from happening, fix all the wiring cables to the installation panel.
- Wiring of the Strain Input Module (-NDI)
When connecting a bridge head, in order that the empty weight of the cable does not exceed 5 kg, ensure that the cable does not hang down more than 1.5 m (the distance to the floor). If it does, secure the cable to the installation panel or some other location.
- Do not apply a voltage exceeding the value indicated below to the input terminals of the input module. The module may become damaged.

Module Type	Max. Input Voltage	Max. Common Mode Voltage	
		Between Channels	Input to Ground
Universal input module	± 10 VDC: Voltage range of 1 VDC or less, TC, RTD, and DI (contact)	-H04: 250 VACrms (50/60 Hz)	600 VACrms (50/60 Hz)
	± 120 VDC: Voltage range of 2 VDC or more, and DI (LEVEL)	-M10: 120 VACrms (50/60 Hz)	

2.4 Connecting the Signal Wires

Module Type	Max. Input Voltage	Max. Common Mode Voltage	
		Between Channels	Input to Ground
DCV/TC/DI input module	± 10 VDC: Voltage range of 1 VDC or less, TC, and DI (contact)	120 VACrms (50/60 Hz)	600 VACrms (50/60 Hz)
	± 120 VDC: Voltage range of 2 VDC or more, and DI (LEVEL)		
Four-wire RTD resistance input module	± 10 VDC: Voltage range of 1 VDC or less, RTD, resistance, and DI (contact)	Voltage: 120 VACrms (50/60 Hz) RTD and resistance: 50 VACrms (50/60 Hz)	600 VACrms (50/60 Hz)
	± 120 VDC: Voltage range of 2 VDC or more, and DI (LEVEL)		
Strain input module	± 10 VDC	30 VACrms (50/60 Hz)	-B12 and -B35: 250 VACrms (50/60Hz) -NDI: 30 VACrms (50/60Hz)
Digital input module	-D05: ± 10 VDC -D24: ± 50 VDC	-	250 VACrms (50/60 Hz)

Module Type	Max. Input Voltage	Max. Common Mode Voltage	
		Between Channels	Output to Ground
Analog/PWM output module	-	-	250 VACrms (50/60 Hz)
Digital output module	250 VAC or 250 VDC	-	250 VACrms (50/60 Hz)

- The MX100 is a measurement category II (IEC61010-1) and installation category II (CSA1N.61010-1) instrument.

Consider the points indicated below to prevent noise from entering the measurement circuit. For a description of the measures against noise on the MX100, see section 2.7.

- Keep the measurement circuit away from the power supply cable (power supply circuit) and ground circuit.
- It is desirable that the object under measurement is not a noise source. However, if this is not avoidable, insulate the object under measurement and the measurement circuit. In addition, ground the object under measurement.
- Shielded wires are effective against noise caused by electrostatic induction. As necessary, connect the shield to the ground terminal of the MX100 (make sure this does not lead to grounding at two points).
- Twisting the measurement circuit wires at short intervals is relatively effective against noise caused by electromagnetic induction.
- Make sure to ground the protective ground terminal through a small grounding resistance (less than or equal to 100 Ω).

When using the reference junction compensation of the MX100 through thermocouple input, take measures to stabilize the temperature at the terminal section.

- Always close and secure the terminal cover.
- Do not use thick wires with high heat radiation effects (cross-sectional area of 0.5 mm² or smaller recommended).
- Keep the ambient temperature consistent. Large temperature fluctuations occur in such cases as when a fan nearby is turned ON/OFF.

Connecting the input wires in parallel with other instruments may mutually affect the measured values.

If you need to make a parallel connection:

- Turn OFF burnout.
- Ground each instrument at a single common point.
- Do not turn ON/OFF the instrument while measurement is in progress. It may cause adverse affects on the other instrument.

Note that RTDs and resistors cannot be connected in parallel.

Wiring Procedure

1. Turn OFF the power to the MX100.
2. Loosen the terminal cover attachment screw and lift up the terminal cover.
3. Connect the signal wires to the terminals.
4. Return the terminal cover to the original position and secure it with the screw.
The appropriate screw tightening torque is 0.6 N·m.

For 4-CH, High-Speed Universal Input Module

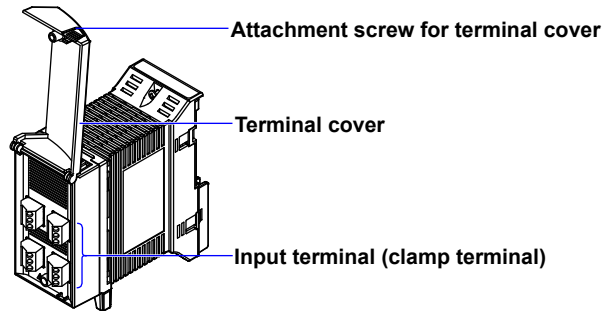

Wiring the Universal Input Module and DCV/TC/DI Input Module

• Thermocouple input

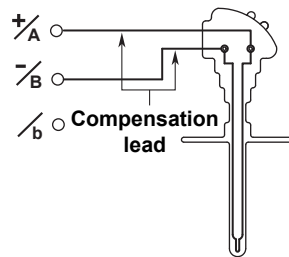

• RTD input

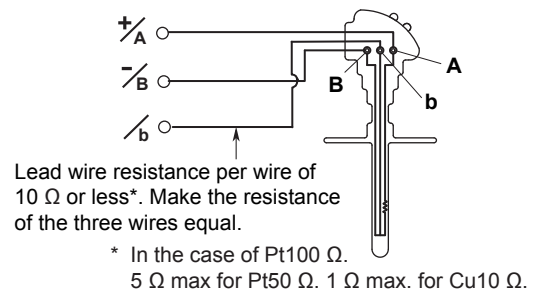

• DC voltage input/DI input (contact)

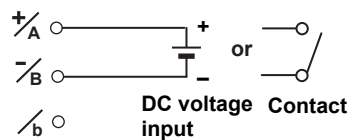

• DC current input

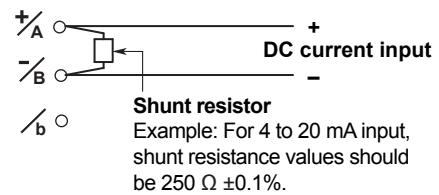

A plate with clamp terminals for current with built-in shunt resistance can be attached to the 10-CH, Medium-Speed Universal Input Module.

- Terminal type: Clamp, or screw (in the case of M3: -L30/H3)
 Applicable wire size: For -H04, 0.2 to 2.5mm² (AWG24 to 12)
 For -M10 and -L30 (clamp), 0.14 to 1.5mm² (AWG26 to 16)

Note

- On the 10-CH, Medium-Speed Universal Input module, RTD input terminals A and B are isolated on each channel. Terminal b is shorted internally across all channels.
- Measurement using RTDs cannot be performed with the 30-CH, Medium-Speed DCV/TC/DI Input Module.
- When the screw terminal plate (model 772080) is connected to the 10-CH, Medium-Speed Universal Input Module, the terminal arrangement differs from that of clamped terminals, so wire according to the markings on the terminal cover.

Wiring the Four-Wire RTD Resistance Input Modules

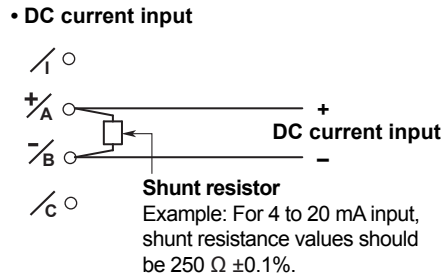
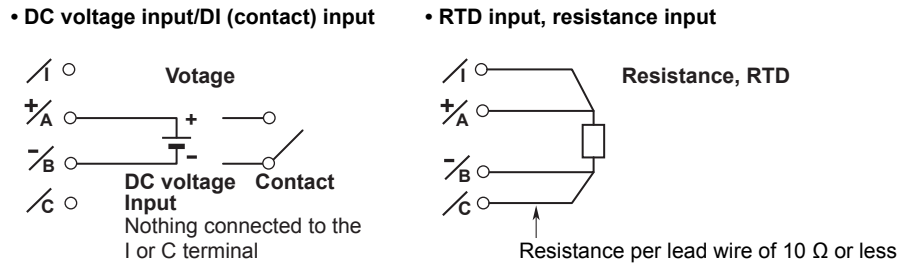

Teraminal type: Clamp
Applicable wire size: 0.14 to 1.5mm² (AWG26 to 16)

Wiring the Strain Input Modules

- One-Gauge Method

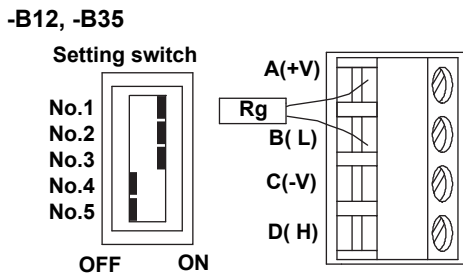
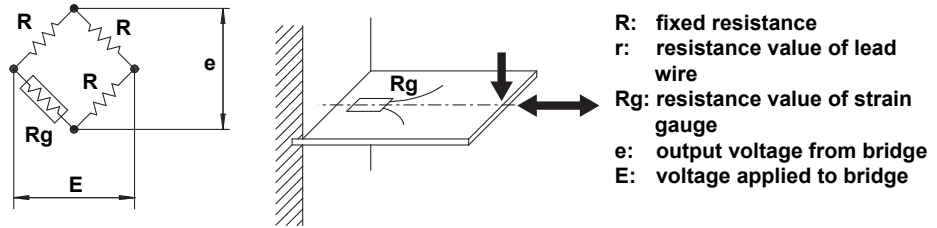

No.1	No.2	No.3	No.4	No.5
ON	ON	ON	OFF	OFF

-NDI Bridge head (701955 or 701956)

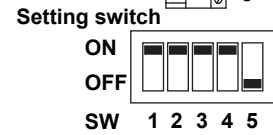
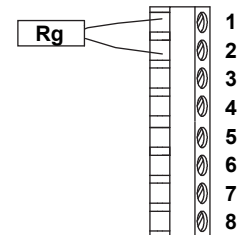

SW1	SW2	SW3	SW4	SW5
ON	ON	ON	ON	OFF

• One-Gauge Three-Wire Method

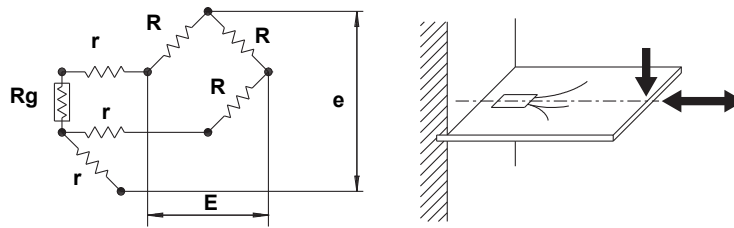

R: fixed resistance
 r: resistance value of lead wire
 Rg: resistance value of strain gauge
 e: output voltage from bridge
 E: voltage applied to bridge

-NDI Bridge head (701955 or 701956)

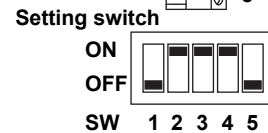
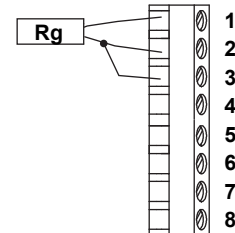

SW1	SW2	SW3	SW4	SW5
OFF	ON	ON	ON	OFF

-B12, -B35

Setting switch

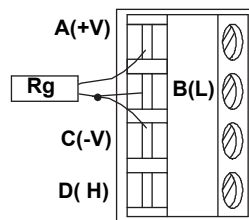
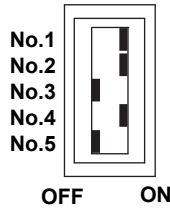

No.1	No.2	No.3	No.4	No.5
ON	ON	OFF	ON	OFF

• Adjacent Two-Gauge Method

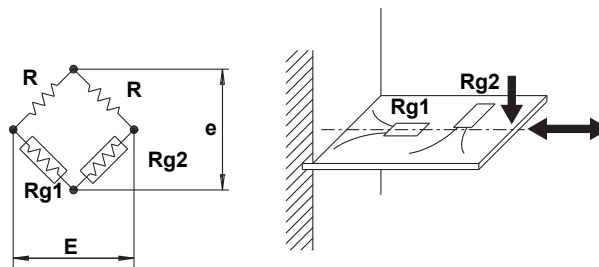

R: fixed resistance
 r: resistance value of lead wire
 Rg: resistance value of strain gauge
 e: output voltage from bridge
 E: voltage applied to bridge

-NDI Bridge head (701955 or 701956)

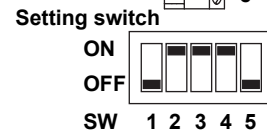
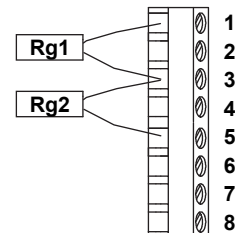

SW1	SW2	SW3	SW4	SW5
OFF	ON	ON	ON	OFF

-B12, -B35

Setting switch

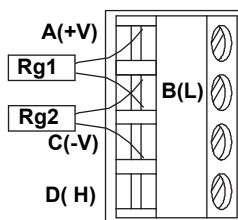
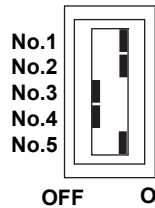

No.1	No.2	No.3	No.4	No.5
ON	ON	OFF	OFF	ON

2.4 Connecting the Signal Wires

• Opposing Two-Gauge Method

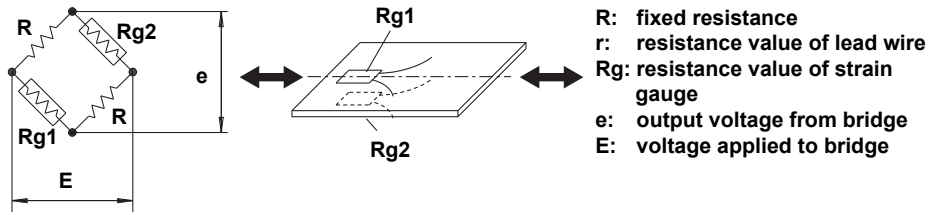

-B12, -B35

Setting switch

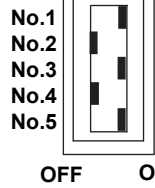

No.1	No.2	No.3	No.4	No.5
ON	OFF	ON	OFF	ON

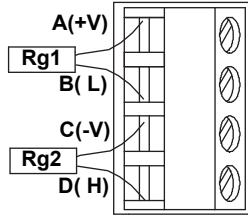

-NDI Bridge head (701955 or 701956)

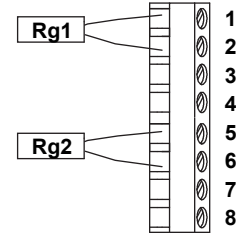

Setting switch

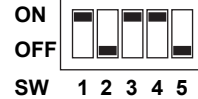

SW1	SW2	SW3	SW4	SW5
ON	OFF	ON	ON	OFF

• Opposing Two-Gauge Three-Wire Method

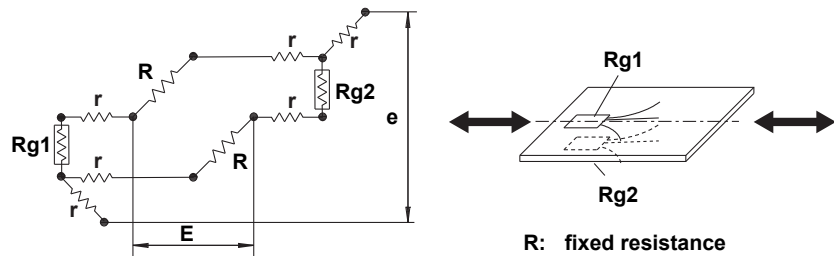

-B12, -B35

Cannot be connected. Use -NDI.

R: fixed resistance
 r: resistance value of lead wire
 Rg: resistance value of strain gauge
 e: output voltage from bridge
 E: voltage applied to bridge

-NDI Bridge head (701955 or 701956)

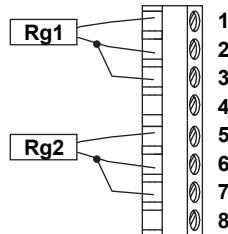

Setting switch

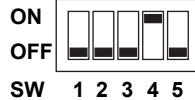

SW1	SW2	SW3	SW4	SW5
OFF	OFF	OFF	ON	OFF

• Four-Gauge Method

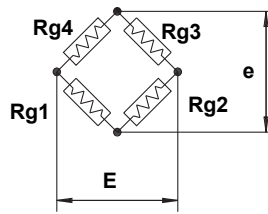

R: fixed resistance
 r: resistance value of lead wire
 Rg: resistance value of strain gauge
 e: output voltage from bridge
 E: voltage applied to bridge

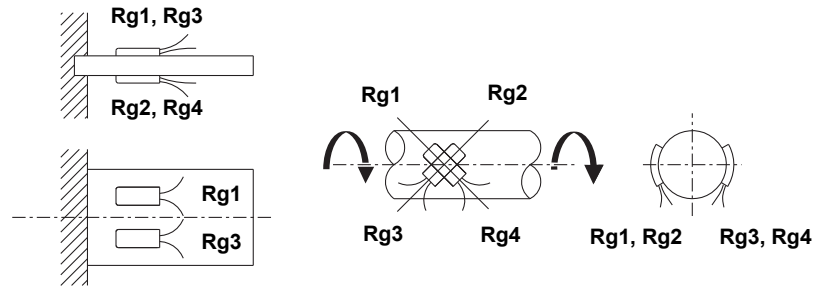

-B12, -B35

Setting switch

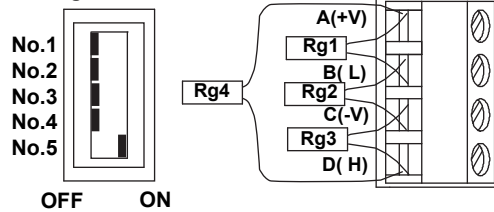

No.1	No.2	No.3	No.4	No.5
OFF	OFF	OFF	OFF	ON

-NDI

Bridge head
 (701955 or 701956)

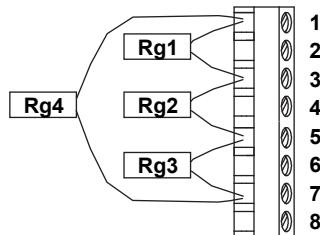

Setting switch

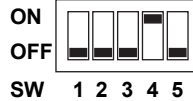

SW1	SW2	SW3	SW4	SW5
OFF	OFF	OFF	ON	OFF

Wiring the Digital Input Modules (-D05, -D24)

Note

- With the digital input module, the (-) terminal and unassigned terminals on all channels are shorted internally.
- When the screw terminal plate (model 772080) is connected to the digital input module, the terminal arrangement differs from that of clamp terminals, therefore wire according to the markings on the terminal cover.

Wiring with the -D05 Option

• Contact input

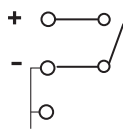

• Transistor input

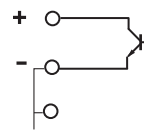

• 5V logic input

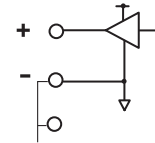

Main Input Specifications (-D05)

Input type:	DI (non-voltage contact, open collector, and 5 V logic)
Input format:	Pull-up at approximately 5 V/approximately 5 k Ω , common electric potential between channels
Min. detection pulse width:	Twice the sampling interval or more
Input threshold level:	Non-voltage contact, open collector: ON at 100 Ω or less and OFF at 100 k Ω or greater 5-V logic: OFF at 1 V or less and ON at 3 V or greater
Contact/transistor rating:	Contact with a rating of 15 VDC or greater and 30 mA or greater Vce and Ic are transistors with ratings of 15 VDC or more, and 30 mA or more, respectively.
Terminal type:	Clamp
Applicable wire size:	0.14 to 1.5 mm ² (AWG26 to 16)

Wiring with the -D24 Option

• 24 V logic input

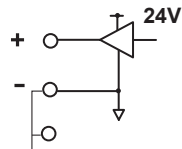

Main Input Specifications (-D24)

Input type:	DI (24 V logic)
Input format:	Common potential between ch
Min. detection pulse width:	Twice the sampling interval or more
Input threshold level:	24 V logic: OFF at 6 V or less and ON at 16 V or greater
Terminal type:	Clamp
Applicable wire size:	0.14 to 1.5 mm ² (AWG26 to 16)

Wiring the Analog Output Modules

External power supply

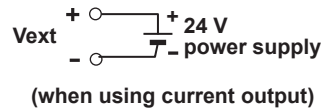

Voltage

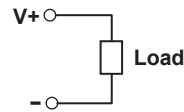

Current

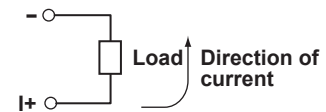

CAUTION

Two power supply terminals are connected internally. Therefore, do not connect a separate external power supply to them as fire can result.

Main Output Specifications

Terminal type:	Clamp, attached and removed in units of 4 channels
Load impedance:	Voltage 5 k Ω or more Current 600 Ω or less
Applicable wire size:	0.08 to 2.5 mm ² (AWG28 to 12)

Wiring the PWM Output Modules

External power supply

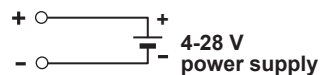

Pulse width output

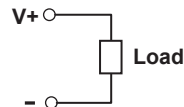

CAUTION

Two power supply terminals are connected internally. Therefore, do not connect a separate external power supply to them as fire can result.

Main Output Specifications

Output capacity:	1A/ch max, however, 4 A or less total for all modules ^{*1, *2}
Terminal type:	Clamp, attached and removed in units of 4 channels
Applicable wire size:	0.08 to 2.5 mm ² (AWG28 to 12)

^{*1} A 1A current limit circuit is built in to the output circuit. Once the current limit circuit is ON, the circuit continues to operate unless the external power supply is turned OFF.

^{*2} This module has a built-in fuse. The built-in fuse protects against fires or abnormal emissions of heat due to load short-circuiting or other abnormalities.

Wiring the Digital Output Modules

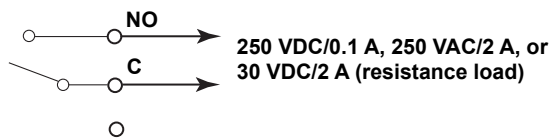

Main Output Specifications

- Contact mode: A contact (SPST)
- Contact capacity: 250 VDC/0.1 A, 250 VAC/2 A, or 30 VDC/2 A (resistance load)
- Terminal type: Clamp, attached and removed in units of 5 channels
- Applicable wire size: 0.08 to 2.5 mm² (AWG28 to 12)

Note

Do not connect anything to the unassigned terminals of the digital output module.

2.5 Power Connection and ON/OFF



WARNING

- To prevent the possibility of electric shock when wiring, confirm that the power supply source is turned OFF.
- To prevent an electric shock or fire, use only power cords supplied by YOKOGAWA for the MX100.
- Make sure to perform protective earth grounding to prevent electric shock. Connect the power cord for the MX100 to a three-prong power outlet with a protective earth terminal. The AC outlet must be of a three-prong type with a protective earth ground terminal.
Do not use the functional ground terminal (see section 2.2, "Installation") as a protective earth terminal.
- Do not use an extension cord without protective earth ground. Otherwise, the protection function will be compromised.

Use a power supply that meets the conditions indicated below.

Item	Specification
Rated supply voltage	100-240 VAC rms
Supply voltage range used	AC power supply, 90 to 250 VAC rms
Rated supply voltage frequency	50/60 Hz
Allowable line frequency range	50/60 Hz \pm 2%
Maximum power consumption	Up to approximately 70 VA maximum when six modules are used

Note

Do not use a supply voltage in the range 132 to 180 VAC, as this may have adverse effects on the measurement accuracy.

Connections with the Power Cord (Power Supply/Cord Basic Specification Code 1□*)

* □ is D, F, R, Q, or H.

1. Check that the power switch of the main module is OFF.
2. Connect the power cord plug to the power connector of the MX100. (Use the power cord that came with the package.)
3. Connect the plug on the other end of the power cord to the outlet that meets the conditions above.
Use a three-prong power outlet with a protective earth ground terminal.

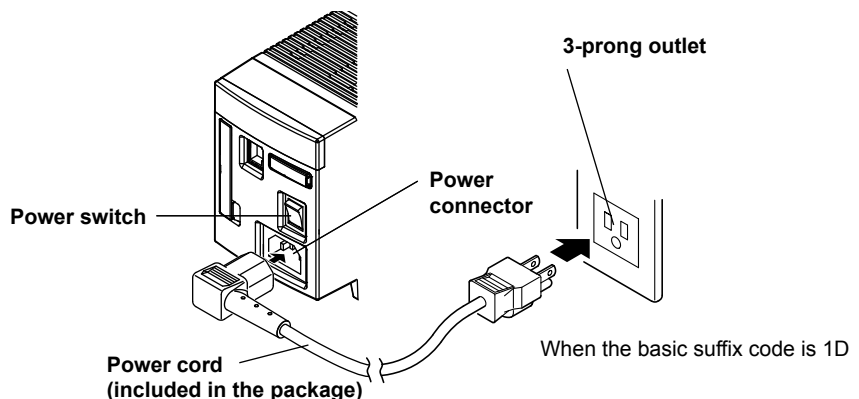

Wiring the Power Supply Terminal (Power Supply/Cord Basic Specification Code 1W)

WARNING

- Set up a switch on the power supply line that shuts off the main power supply to the instrument. Also, include an ON/OFF indicator with the switch as well as a label that identifies the switch as the power shut down switch.

Switch specifications

Steady state current rating: 3 A or more

Inrush current rating: 80 A or more

Conforms with IEC60947-1 and -3

- Connect a fuse of 2 A to 15 A to the power supply line.
- Do not insert a switch or fuse on the ground line.

1. Check that the power switches to the power supply and main module are turned OFF.
2. Loosen the power terminal cover attachment screws on the main module and open the terminal cover.
3. Wire the power supply cord and protective grounding cord to the power supply terminal as shown in the figure below.
Use round crimp-on lugs with isolation sleeves (for 4 mm screws) for the power cord and protective ground cord terminals.
4. Close the power supply terminal cover and secure it with the screw.

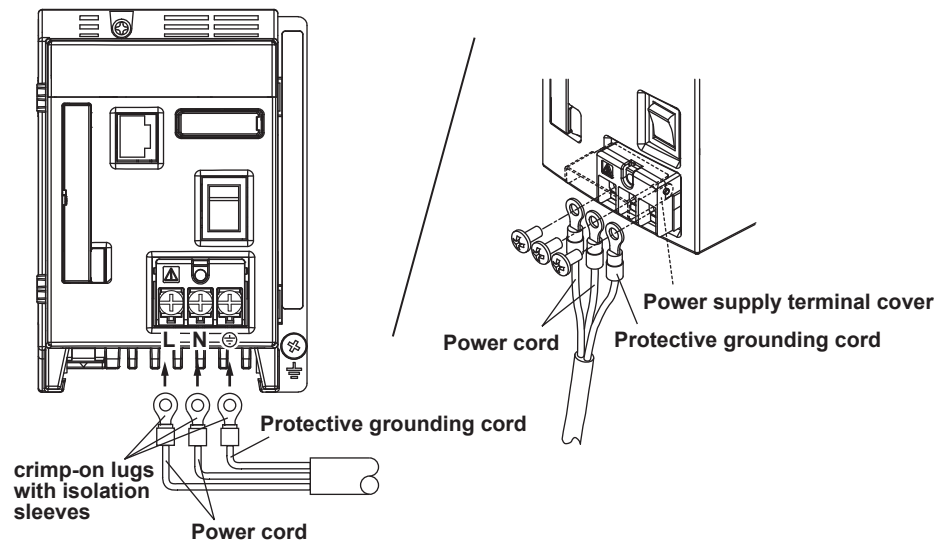

Turning ON/OFF the Power Switch

Pressing the “I” side of the power switch turns the instrument ON. Pressing the “O” side turns the instrument OFF.

When turned ON, the 7-segment LED (see section 1.2, “Main Module Functions”) illuminates. When the instrument is ready (after completing the self-test), the unit number is displayed. When using the MX100 Standard Software, the unit number is fixed at 00 displayed as “00.”

Note

- Before turning the power ON, check that the modules are attached correctly and that the power cord is connected correctly.
- If the 7-segment LED does not illuminate when the power switch is turned ON, turn OFF the power switch and check the points listed below. If the condition does not change when turning ON the power even after checking those items, it is probably a malfunction. Contact your nearest YOKOGAWA dealer for repairs.
 - That the power cord is plugged in properly.
 - That the power supply voltage is within the “supply voltage range used” indicated in this section.
- If the 7-segment LED displays something other than a unit number when the power switch is turned ON, see section 3.1, “Error Display on the 7-Segment LED and Corrective Actions.” and carry out the specified corrective action. If the displayed information does not change even when you carry out the corrective action, it is probably a malfunction. Contact your nearest YOKOGAWA dealer for repairs.

2.6 Connecting the Ethernet Cable

Connection Procedure

Connectors

Connect the Ethernet cable to the Ethernet port (10BASE-T/100BASE-TX) of the main module. Use a UTP cable (category 5 or better) or an STP cable for the Ethernet cable.

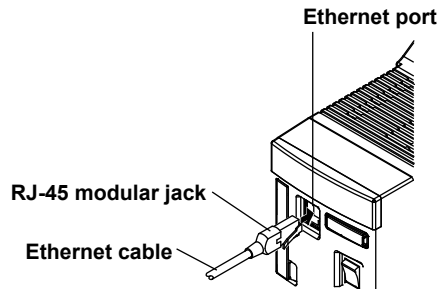

Connection to the PC

Make the connection via a hub. For one-to-one connection with a PC, connect as shown in the figure below. Likewise, up to twenty MX100s can be connected to a single PC. However, to connect two or more MX100s, MXLOGGER (sold separately) must be used instead of the MX100 Standard Software that comes with the instrument.

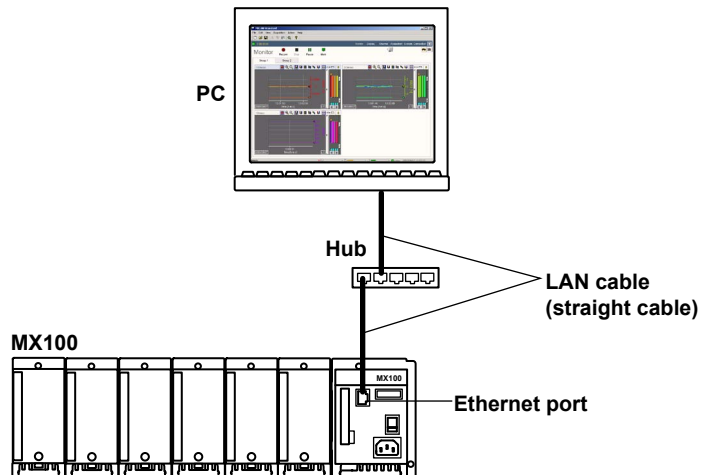

Note

- The NIC on the PC should support 100BASE-TX (recommended) or 10BASE-T.
- When connected to an external network, the communications within the network other than those related to the MX100 may hinder the measurement operations on the MX100.
- The MX100 can be connected to an auto-negotiating hub (between 10BASE-T and 100BASE-TX), but connection may fail on some hubs due to the hub not recognizing the signal output from the MX100. If this happens, you can turn only dip switch 6 of the main module OFF to fix the data rate to 10 Mbps. Operate the dip switch only when the power is turned OFF.

Checking the Communication Status

You can check the status on the two LEDs at the upper-right and lower-right of the Ethernet port.

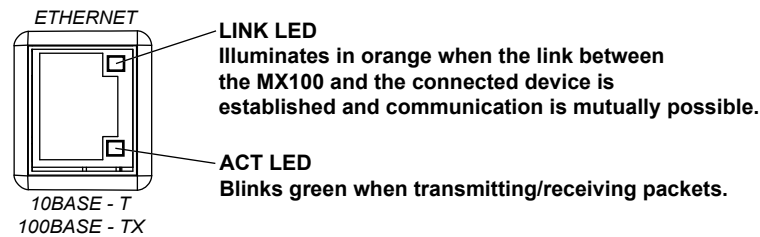

Initializing the Settings

The dip switch on the main module is used to initialize the settings including the IP address assigned to the MX100.

1. Turn OFF the power to the MX100.
2. Turn dip switch 5 of the main module OFF.
3. Turn ON the power to the MX100.
The 7-segment LED indicates the self-test operation at power up (see section 1.2, "Main Module Functions"), and then displays bF.
4. Check the status of step 3, then turn the power OFF.
5. Turn dip switch 5 back ON.
Check that the settings have been initialized (using the MX100 Standard Software, for example).

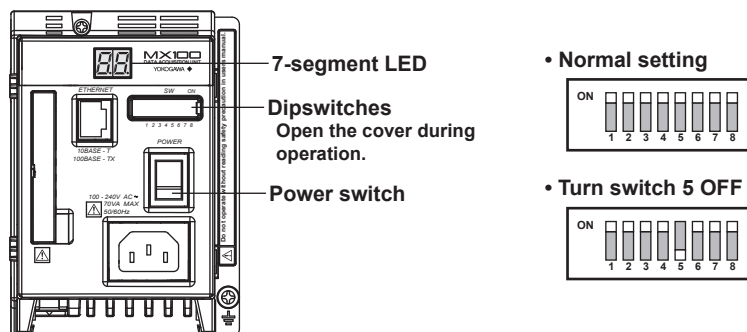

2.7 Measures against Noise on the MX100

Technical Information described below on measures against noise is available as reference material. For information on obtaining a copy, contact your nearest YOKOGAWA dealer.

- Noise Interference on Recorder (TI 4D5B1-80E)
Describes the fundamentals concerning noise and its countermeasures in two parts: basic edition and application edition.
- MX100 Performance Specifications (TI 04M08B01-00E)
Describes in detail the functions related to noise rejection specific to the MX100. This section briefly describes the integrating A/D converter and the first-order lag filter that the MX100 employs as measures against noise.

Integrating A/D Converter

MX100 input modules employ an integrating A/D converter for converting the measured analog signals into digital signals. The integrating A/D converter integrates the measured values at the specified time width. If the specified time width matches the period of the signal you wish to reject, the signal is rejected.

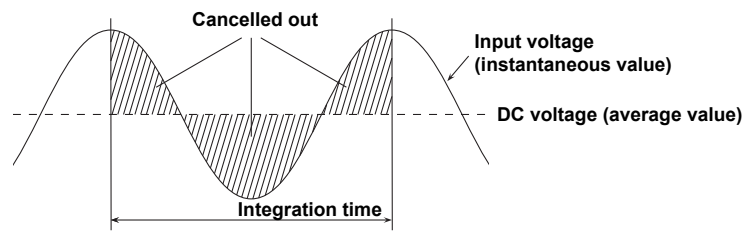

For example, if the integration time is 20 ms, signals having frequencies of 50 Hz and integer multiples of 50 Hz can be rejected. Likewise, if the integration time is 16.67 ms, signals having frequencies of 60 Hz and integer multiples of 60 Hz can be rejected. If the integration time is 100 ms, signals having 10 Hz and integer multiples of 10 Hz can be rejected. The commercial power supply is one of the noise sources. By setting these integration times, commercial power noise of 50 Hz or 60 Hz can be eliminated.

On the MX100, the integral time is determined by the measurement interval setting as shown in the table below.

4-CH, High-Speed Universal Input Module

Measurement Interval	Integration Time	Filter	Rejected Noise and Notes
10 ms	1.67 ms	Rectangular	600 Hz and its integer multiples*
50 ms	16.67 ms		60 Hz and its integer multiples
	20 ms		50 Hz and its integer multiples
	Auto		Automatically detects the power supply frequency and set 16.67 or 20 ms
100, 200 ms	36.67 ms	Trapezoidal	50 Hz or 60 Hz and their integer multiples
500 ms	100 ms	Rectangular	10 Hz and its integer multiples
1, 2, 5, 10, 20, 30, 60 s	200 ms	Cos	Fc = 5-Hz low-pass filter

* Since the power supply frequency noise is not rejected, the measured values may fluctuate especially with temperature measurement. In such cases, set the measurement interval to 50 ms or higher.

10-CH, Middle-Speed Universal Input Module/6-CH, Medium-Speed Four-Wire RTD Resistance Input Module

Measurement Interval	Integration Time	Filter	Rejected Noise and Notes
100, 200 ms	1.67 ms	Rectangular	600 Hz and its integer multiples*
500 ms	16.67 ms		60 Hz and its integer multiples
	20 ms		50 Hz and its integer multiples
	Auto		Automatically detects the power supply frequency and set 16.67 or 20 ms
1 s	36.67 ms	Trapezoidal	50 Hz or 60 Hz and their integer multiples
2 s	100 ms	Rectangular	10 Hz and its integer multiples
5, 10, 20, 30, 60 s	200 ms	Cos	Fc = 5-Hz low-pass filter

* Since the power supply frequency noise is not rejected, the measured values may fluctuate especially with temperature measurement. In such cases, set the measurement interval to 500 ms or higher, or use the 4-CH, High-Speed Universal Input Module

30-CH, Middle-Speed DCV/TC/DI Input Module

Measurement Interval	Integration Time	Filter	Rejected Noise and Notes
500 ms	1.67 ms	Rectangular	600 Hz and its integer multiples*
1 s	16.67 ms		60 Hz and its integer multiples
	20 ms		50 Hz and its integer multiples
	Auto		Automatically detects the power supply frequency and set 16.67 or 20 ms
2 s	36.67 ms	Trapezoidal	50 Hz or 60 Hz and their integer multiples
5, 10, 20, 30, 60 s	100 ms	Rectangular	10 Hz and its integer multiples

* Since the power supply frequency noise is not rejected, the measured values may fluctuate especially with temperature measurement. In such cases, set the measurement interval to 1 s or higher, or use the 4-CH, High-Speed Universal Input Module or the 10-CH, Medium-Speed Universal Input Module.

4-CH, Medium-Speed Strain Input Module

Measurement Interval	Integration Time	Filter	Rejected Noise and Notes
100 ms	1.67 ms	Rectangular	600 Hz and its integer multiples*
200 ms	16.67 ms		60 Hz and its integer multiples
	20 ms		50 Hz and its integer multiples
	Auto		Automatically detects the power supply frequency and set 16.67 or 20 ms
500 ms	36.67 ms	Trapezoidal	50 Hz or 60 Hz and their integer multiples
1 s	100 ms	Rectangular	10 Hz and its integer multiples
2, 5, 10, 20, 30, 60 s	200 ms	Cos	Fc = 5-Hz low-pass filter

* Since the power supply frequency noise is not rejected, the measured values may fluctuate. In such cases, set the measurement interval to 200 ms or higher.

First-Order Lag Filter

For noise sources other than power supply noise, the MX100 is equipped with a first-order lag filter having output characteristics indicated in the figure below against step input. The time constant of the first-order lag filter can be selected on the PC software (MX100 Standard Software, MXLOGGER (sold separately), or the API for the MX100/DARWIN (sold separately)).

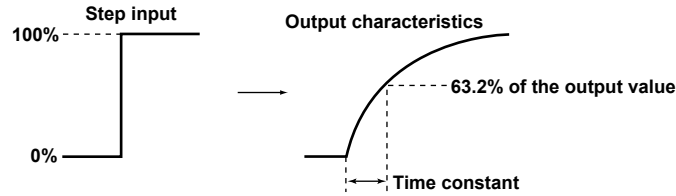

Measurement Interval (s)	Selectable Time Constants (s)						
	n=5	n=10	n=20	n=25	n=40	n=50	n=100
0.01	0.05	0.1	0.2	0.25	0.4	0.5	1
0.05	0.25	0.5	1	1.25	2	2.5	5
0.1	0.5	1	2	2.5	4	5	10
0.2	1	2	4	5	8	10	20
0.5	2.5	5	10	12.5	20	25	50
1	5	10	20	25	40	50	100
2	10	20	40	50	80	100	200
5	25	50	100	125	200	250	500
10	50	100	200	250	400	500	1000
20	100	200	400	500	800	1000	2000
30	150	300	600	750	1200	1500	3000
60	300	600	1200	1500	2400	3000	6000

If the first-order lag filter is applied to the input signal, low-pass filter frequency characteristics shown in the figure below are attained.

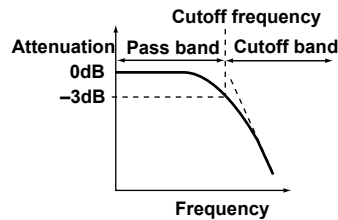

If the time constant of the first-order lag filter is set long, the cutoff frequency is lowered, and frequency bandwidth that can be rejected is widened. Set an appropriate time constant according to the frequency of the noise you wish to reject.

2.8 Handling of the CF Card

Handling Precautions of the CF Card

Note the following points when using the CF card. For the general handling precautions of the CF card, see the instruction manual that came with the card.

- The CF card is a precision electronic device. Do not use or store the CF card in an environment with strong static electricity or an environment where electric noise tends to appear.
- Do not remove the CF card from the card slot while data is being written. Doing so can damage or erase the data.

Inserting the CF Card

To insert the CF card into the card slot, open the slot cover and face the card's front side to the right.

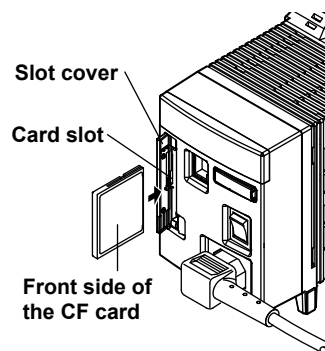

Ejecting the CF Card

Be sure to check that the CF card is not being accessed before ejecting the card from the slot. When the CF card is being accessed, the 7-segment LED indicates this fact (see section 1.2, "Contents Displayed on the 7-Segment LED").

To eject the CF card, open the slot cover while touching the metal for discharging the static electricity, and press the eject lever once. Then, press the eject lever that came out once again, and remove the CF card from the slot.

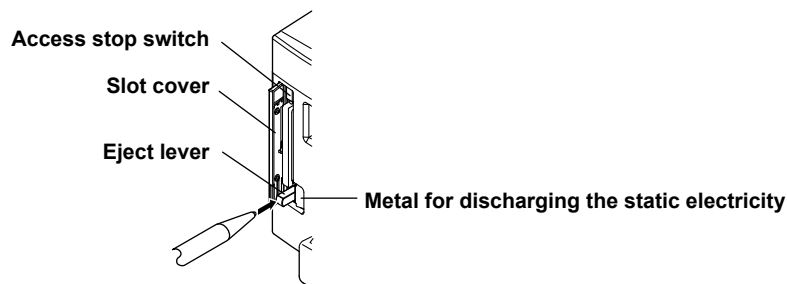

Note

- If it is difficult to press the eject lever with your finger, use an object with a narrow tip such as a pen as shown in the figure above.
- Do not close the slot cover by force when the eject lever is out. Doing so can damage the CF card slot. When not using the eject lever, push the lever in so that the slot cover can be closed.
- If you need to eject the CF card while it is being accessed (when the operation mode is backup), open the slot cover and press the access stop switch (see the figure above) at the top section of the slot. After the data save operation to the CF card stops (the displayed operation mode on the 7-segment LED described under "Contents Displayed on the 7-Segment LED" in section 1.2 changes from backup to measurement), eject the CF card.

3.1 Error Display on the 7-Segment LED and Corrective Actions

The main module has a two-digit 7-segment LED as shown in the figure below. The 7-segment LED displays the system status. This section describes the displays on the 7-segment LED when errors occur on the system and their corrective actions. For normal displays other than errors, see “Contents Displayed on the 7-Segment LED” in section 1.2.

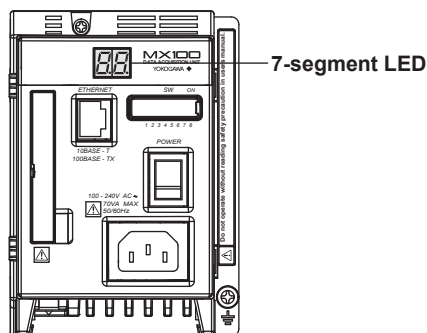

If servicing is necessary, or if the instrument is not operating correctly after performing the corrective actions below, contact your nearest YOKOGAWA dealer.

Errors at Power ON

The left and right digits of the 7-segment LED display “b” and an error code, respectively. The LED illuminates.

Probable Cause	Corrective Action	Ref. Page
The display is b* (where * is any character other than F). The dip switch settings are not correct.	Turn OFF the power, eject the CF card, turn ON all dip switches, and start up again. If the situation does not change servicing is required.	2-27
The display is bF. The dip switch settings are not correct.	Powering up in setup reset mode. Turn OFF the power, turn ON all dip switches, and power up again. Since all settings such as the IP address are initialized, reconfiguration is necessary.	2-23

System Errors

The left and right digits of the 7-segment LED display “F” and an error code, respectively. The LED illuminates.

Display	Probable Cause	Corrective Action	Ref. Page
F0	System ROM error.	Servicing required.	-
F1	SRAM error	Servicing required.	-
F2	EEPROM error	Servicing required.	-
F3	Error in the internal battery of the main module.	Servicing required. However, this error is also displayed immediately after the battery is replaced. If this happens, power-cycle the MX100.	-
F4	Ethernet controller error	Servicing required.	-
F5	Internal data error (only when the /DS option is enabled)	Servicing required.	-

3.1 Error Display on the 7-Segment LED and Corrective Actions

Module Errors

The left and right digits of the 7-segment LED display “E” and an error code, respectively. The LED illuminates. In the case of module errors, the error number and the corresponding module number are displayed alternately as shown in the figure below.

Error number Module number
E *1* → *n* *1*

Display	Probable Cause	Corrective Action	Ref. Page
E0	Range information error.	Servicing required.	-
E1	Calibration value error.	Check the module's installation status, then recalibrate the module. If the error occurs even after recalibrating, servicing is required.	*
E2	Calibration reference voltage value is not correct (during calibration).	Check whether the correct calibration reference voltage is being applied or whether the channel to which the voltage is applied is correct.	*
E3	Error in writing the calibration value.	Servicing required.	-
E4	The installed module cannot be used.	Replace the module with one that can be used.	-
E5	Initial balancing Error (Initial unbalance value adjustment)	Check the module's installation status, then perform initial balancing again. If the error occurs even after recalibrating, servicing is required.	-

* See the MX100 Standard Software User's Manual (IM MX180-01E).

Media-Related Errors

The left and right digits of the 7-segment LED display “P” and an error code, respectively. The LED blinks. The error code is saved to the log file (see “Log File Storage” under “Saving Data to the CF Card” in section 1.2).

Display	Probable Cause	Corrective Action	Ref. Page
P0	Manipulated the CF card while it was being accessed.	Do not manipulate the CF card while it is being accessed.	2-27
P1	CF card error.	The CF card may not be formatted or may be damaged. Check the CF card.	-
P2	The CF card was not formatted correctly.	Insert the CF card into the CF card slot and format the card again, or replace with another CF card.	*
P3	Not enough free space on the CF card.	Delete unneeded data to increase the free space, or replace with another CF card.	*
P4	The number of files saved on the CF card exceeded 512.	Delete unneeded files to decrease the number of files, or replace with another CF card.	*
P5	Overwrite error in the data storage buffer.	The time needed to store the file must be reduced. Delete unneeded data to increase the free space, or format the CF card. If you are using a software application through the MX100/DARWIN API, the timeout setting may not be appropriate. If so, change the value to an appropriate value.	*

* See the MX100 Standard Software User's Manual (IM MX180-01E).

Communication Errors

The left and right digits of the 7-segment LED display “C” and an error code, respectively. The LED blinks.

Display	Probable Cause	Corrective Action	Ref. Page
C1	Multiple connection error.	Disconnect the current connection and reconnect. However, this error may also appear when the Ethernet cable is removed and inserted again.	*

* See the MX100 Standard Software User's Manual (IM MX180-01E).

3.2 Troubleshooting

If servicing is necessary, or if the instrument is not operating correctly after performing the corrective actions below, contact your nearest YOKOGAWA dealer for repairs.

The 7-segment LED does not illuminate.

Probable Cause	Corrective Action	Ref. Page
The power switch is not ON.	Turn ON the power switch.	2-21
The supply voltage is too low.	Check whether the power supply voltage is within the rated range.	2-19
The fuse is blown.	Servicing required.	-
The power supply is broken.	Servicing required.	-

The 7-segment LED blinks repeatedly.

Probable Cause	Corrective Action	Ref. Page
The power supply is shorted inside the input/output module.	Remove the input/output module one by one and determine the broken module (servicing required.)	2-4
The power supply is shorted inside the main module.	Replace the main module. (Servicing required.)	2-4

The MX100 cannot be detected from the PC or cannot be detected with the Search button.

Probable Cause	Corrective Action	Ref. Page
The LINK LED does not turn ON. The cable is broken.	Replace the Ethernet cable.	2-22, 2-23
The LINK LED does not turn ON. There is a problem with the hub.	Check the hub's power supply. If it still does not work, replace the hub and check the hub's operation. Also, try to connect the MX100 using the 10-Mbps fixed mode.	2-22, 2-23
The LINK LED does not turn ON. There is a problem with the PC.	Check whether the PC can connect to the network. Replace the PC's NIC.	2-22, 2-23
The ACT LED does not turn ON. There is a problem in the connection between the hub and the MX100.	Check the hub's power supply. If it still does not work, replace the hub and check the hub's operation. Also, try to connect the MX100 using the 10-Mbps fixed mode.	2-22, 2-23
The ACT LED does not turn ON. There is a problem with the PC.	Check whether the PC can connect to the network. Replace the PC's NIC.	2-22, 2-23
There is a problem in the network configuration. The settings are not correct.	Check that the IP address, subnet mask, and default gateway settings of the PC correspond to the MX100 settings.	*
There is a problem in the network configuration. The setting changes have not taken effect.	Turn OFF the power to the PC and the MX100, and carry out reconnection.	2-21, *
There is a problem in the software created using the MX100/DARWIN API.	Check whether the connection can be made using the MX100 Standard Software.	*
The PC and the MX100 are not in the same segment.	Connect the PC and the MX100 in the same network segment. When connected as shown in the following figure, the Search button cannot be used to detect the MX100, but you can make the connection by manually specifying the IP address of the MX100.	*

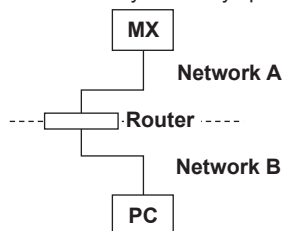

When using Windows XP or Windows Vista, check the firewall function.

* See the MX100 Standard Software User's Manual (IM MX180-01E).

3.2 Troubleshooting

The MX100 can be detected using the Search button, but connection fails.

Probable Cause	Corrective Action	Ref. Page
The IP address is set to the default value. The default value cannot be used to make the connection.	Set the correct IP address.	*
There is a problem in the network configuration.	Check that the IP address, subnet mask, and default gateway settings of the PC and the MX100 settings are correct.	*
The PC software, main module style number, and release number rule is not upheld.	Check the PC software release number and main module style number before upgrading the version. [PC software release no.] ≥ [main module style no.]	i

* See the MX100 Standard Software User's Manual (IM MX180-01E).

The Calibrator cannot connect to the MX100.

Probable Cause	Corrective Action	Ref. Page
Attempting to make multiple connections. Another software program such as the MX100 Standard Software is already connected.	Close all other software programs such as the MX100 Standard Software.	*
The main module and input/output module style number rule is not upheld.	Check the release number of the PC software and the main module style number, then upgrade the version. [PC software release no.] ≥ [main module style no.] ≥ [input/output module style no.]	i

* See the MX100 Standard Software User's Manual (IM MX180-01E).

The connected input/output module is not detected.

Probable Cause	Corrective Action	Ref. Page
Module connection or module startup error. Attached the module while the power was ON.	Turn OFF the power. Detach the input/output module once and attach it again.	2-4, 2-19
The PC software, main module, and input/output module style and release number rule is not upheld.	Check the PC software release number and main module style number before upgrading the version. [PC software release no.] ≥ [main module style no.] ≥ [input/output module style no.]	i
Carried out an incorrect calibration.	Recalibrate.	*
The 10-CH, Pulse Input Module (MX114-PLS-M10) is connected.	The 10-CH, Pulse Input Module cannot be used with the MX100. Use this module with the MW100.	1-5

* See the MX100 Standard Software User's Manual (IM MX180-01E).

The measured value is not correct.

Probable Cause	Corrective Action	Ref. Page
The input wiring is not correct.	Check the input wiring.	2-11 to 2-18
The measured value indicates +Over or Over. The measurement range setting and input range do not match.	Change to an appropriate setting.	*
The temperature error is large or is unstable. The TC type setting and the type actually connected are different.	Change to the correct setting.	*
The temperature error is large or is unstable. The RJC setting is not correct.	Change to the correct setting.	*
The temperature error is large or is unstable. The wind is hitting the terminals.	Block the wind from hitting the terminals.	-
The temperature error is large or is unstable. The ambient temperature change is drastic.	Suppress changes in the ambient temperature such as by placing the MX100 in a box.	-
The temperature error is large or is unstable. There is an error in the wiring resistance (in the case of an RTD).	Match the thickness and length of the three input wires.	2-11
The measurement error is large or is unstable.	Take measures against noise effects.	2-24
The measurement error is large or is unstable. Effects from the signal source resistance.	Reduce the signal source resistance such as by inserting a converter.	-
The temperature error is large or is unstable. Effects from parallel connections.	Stop parallel connections. Do not use the burnout setting.	-
Measured values from the strain gauge type sensor are not correct.	When using a sensor without a remote sensing wire, use the DV450-001 (conversion cable).	-
On the strain module (-B12, -B35), the gauge method and dip switch settings are not correct.	Enter the correct settings.	2-12 to 2-15
On the strain module (-B12, -B35), the gauge resistance and internal bridge resistance values are different.	Use a module that supports the resistance value of the strain gauge (For 120 Ω , -B12, and for 350 Ω , -B35).	2-12 to 2-15
On the strain module, scaling is not set appropriately according to the gauge method. (for 2 gauge, 4 gauge methods, the amount of strain is doubled or quadrupled.)	Displayed with 1 gauge method conversion. Set scaling appropriately according to the gauge.	4-23
On the strain module (-NDI), a strain gauge type sensor without a remote sensing wire is being used.	When using a sensor without a remote sensing wire, use the DV450-001 (conversion cable).	-

* See the MX100 Standard Software User's Manual (IM MX180-01E).

Alarms are not output.

Probable Cause	Corrective Action	Ref. Page
There is a problem in the alarm setting.	Make the alarm and output relay settings appropriate. Both the alarm and output relay must be set appropriately.	*

* See the MX100 Standard Software User's Manual (IM MX180-01E).

The CF card is not detected.

Probable Cause	Corrective Action	Ref. Page
There is a problem with the CF card.	Replace the CF card. Eject and format the CF card, then insert it again.	2-27

3.3 Calibration

It is recommended that the MX100 be calibrated once a year to assure its measurement accuracy. A calibration instrument with an appropriate accuracy and resolution is required for calibrating the MX100.

Range Calibration of DC Voltage, RTD, Resistance, Strain, and Analog Output

Required Instruments

- DC voltage/current standard
Must meet the following specifications (M/9100 by FLUKE or equivalent)
Output range: 20 mV to 100 V
Accuracy in the output range: $\pm(0.01\% + 1 \mu\text{V})$ or less
- Resistance standard
Must meet the following specifications (ADR3204 by Alpha Electronics or equivalent)
Resistance setting range (resolution): 0.2 to 1999 Ω (0.001 Ω), 0.2 to 19999 Ω (0.01 Ω)
Resistance accuracy of the resistance setting range: $\pm(0.01\%$ of rdg + 2 m Ω) or less
 - * For calibrating the Universal Input Module and 6-CH Medium-Speed, Four-Wire Resistance Input module
- Bridge head (Yokogawa Electric model 701955 and 701956)
- Digital multimeter
Must meet the following specifications (7562 by Yokogawa Electric or equivalent)
Accuracy: $\pm 0.01\%$ or less

Calibration Procedure

1. Wire the module being calibrated and the calibration instrument as shown in the figure below, and adequately warm up the MX100 (the warm-up time of the MX100 is at least 30 minutes).
2. Check that the operating environment such as ambient temperature and humidity is within the standard operating conditions (see sections 4.4 through 4.8).
3. Connect the PC and the MX100 so that communication is possible. Start the Calibrator of the MX100 Standard Software, and then start the calibration.
For the operating procedure of the Calibrator, see the MX100 Standard Software User's Manual (IM MX180-01E).

Wiring Diagram

- When calibrating the DC voltage range of the 4-CH, High-Speed Universal Input module

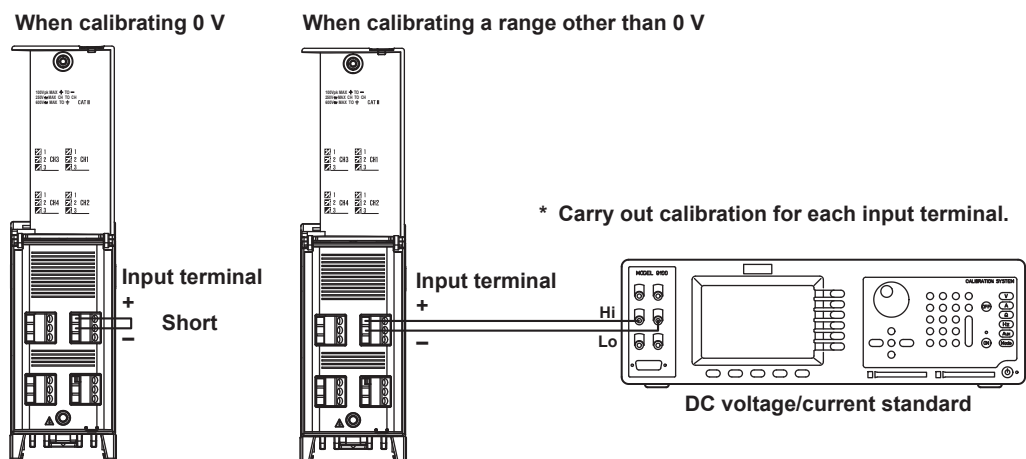

- When calibrating the RTD range of the 4-CH, High-Speed Universal Input module

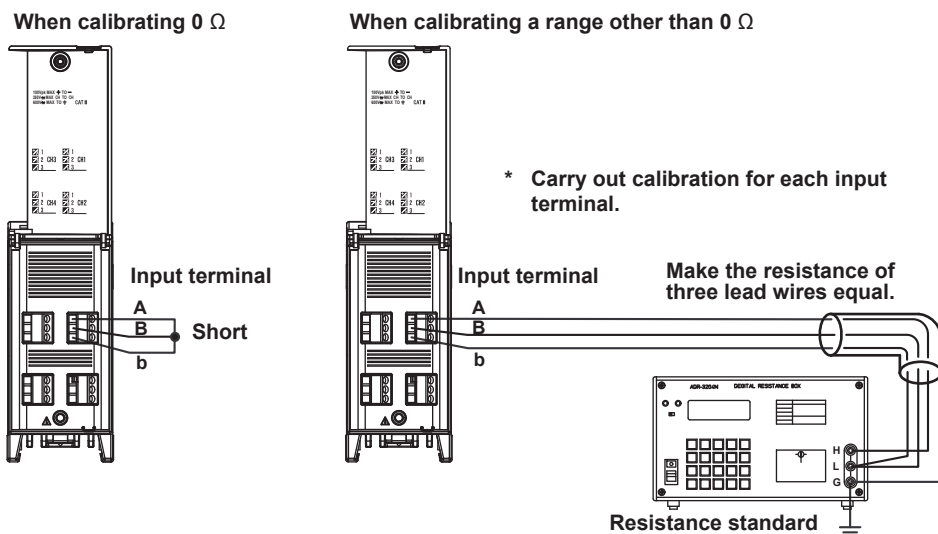

- When calibrating the DC voltage range of the 10-CH, Medium-Speed Universal Input module

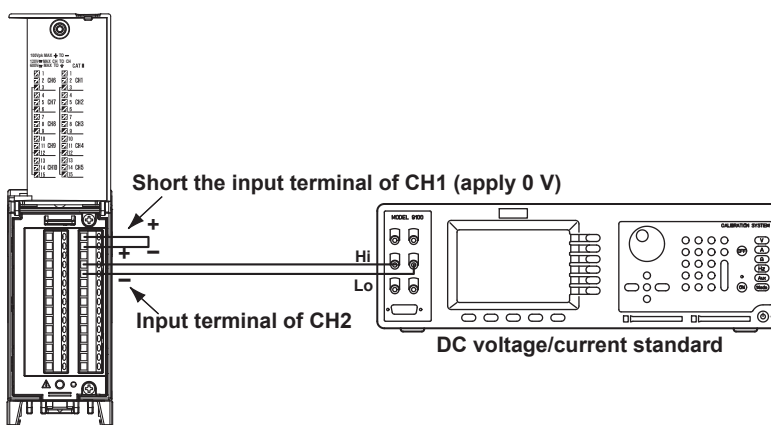

- When calibrating the RTD range of the 10-CH, Medium-Speed Universal Input module

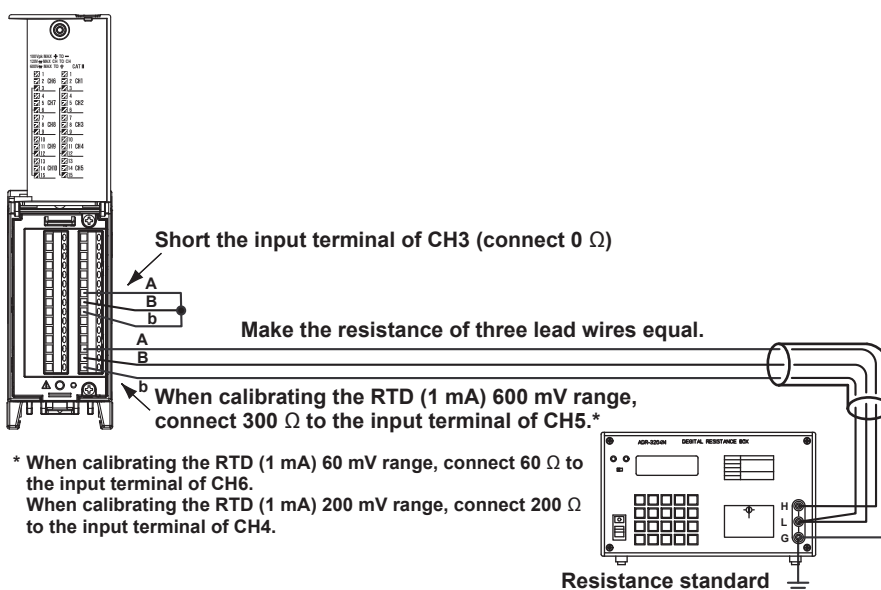

* When calibrating the RTD (1 mA) 60 mV range, connect 60 Ω to the input terminal of CH6.
When calibrating the RTD (1 mA) 200 mV range, connect 200 Ω to the input terminal of CH4.

3.3 Calibration

- When calibrating the DC voltage range of the 30-CH, Medium-Speed DCV/TC/DI Input module

For MX110-VTD-L30

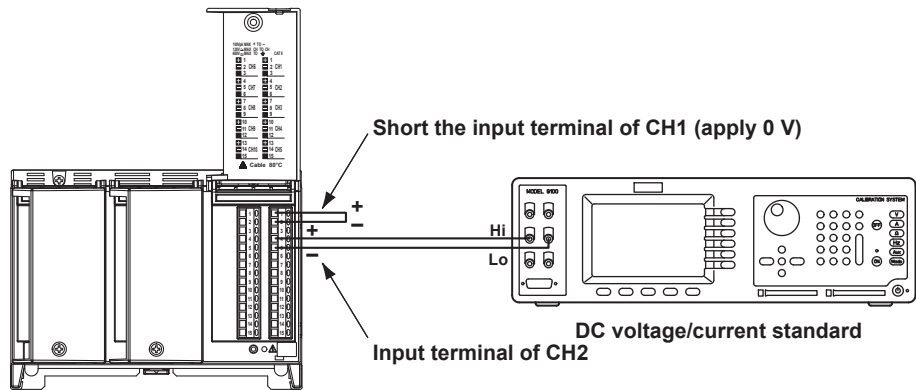

For MX110-VTD-L30/H3

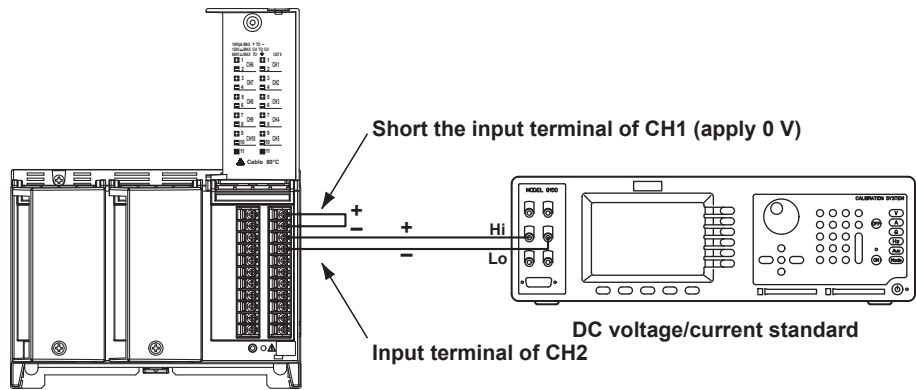

- When calibrating the DC voltage range of the 6-CH, Medium-Speed Four-Wire RTD Input module

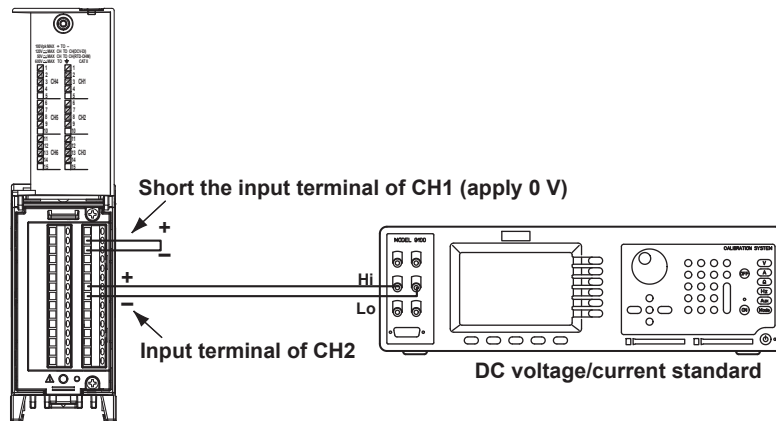

- When calibrating the RTD or resistance range of the 6-CH, Medium-Speed Four-Wire RTD Resistance Input module

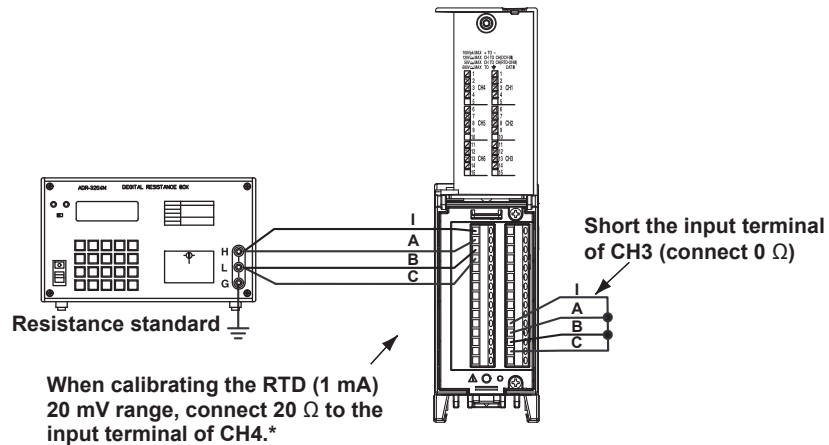

- * When calibrating the RTD (1 mA) 60 mV range, connect 60 Ω to the input terminal of CH5.
- When calibrating the RTD (1 mA) 200 mV range, connect 200 Ω to the input terminal of CH6.
- When calibrating the RTD (1 mA) 600 mV range, connect 300 Ω to the input terminal of CH4.
- When calibrating the RTD (0.25 mA) 600 mV range, connect 2400 Ω to the input terminal of CH5.
- When calibrating the RTD (0.25 mA) 1 V range, connect 3000 Ω to the input terminal of CH6.

- When calibrating the range of the 4-CH, Medium-Speed Strain Module (-B12, -B35, and -NDI)

The clamp terminal (-B12, -B35) and NDIS terminal (-NDI) are connected with the 4-gauge method (see below and next page). Resistors R1-R3 use 120 Ω, and a resistance corresponding to the Zero or Full value is connected to R4. To correctly calibrate the range, do so in the order Zero, then Full.

Calibration Range	Res. R1, R2, and R3		Res. R4		Resistance value accuracy
	Zero	Full*	Zero	Full*	
2000 μstrain	120.000 Ω	120.000 Ω	117.154 Ω	117.154 Ω	±0.005%, ±0.3ppm/°C
20000 μstrain	120.000 Ω	120.000 Ω	113.010 Ω	113.010 Ω	±0.005%, ±0.3ppm/°C
200000 μstrain	120.000 Ω	120.000 Ω	80.000 Ω	80.000 Ω	±0.005%, ±0.3ppm/°C

- * The Full calibration value of 2000 μstrain range is approximately to 12000 μstrain
- The Full calibration value of 20000 μstrain range is approximately to 30000 μstrain
- The Full calibration value of 200000 μstrain range is approximately to 200000 μstrain

For -B12, -B35

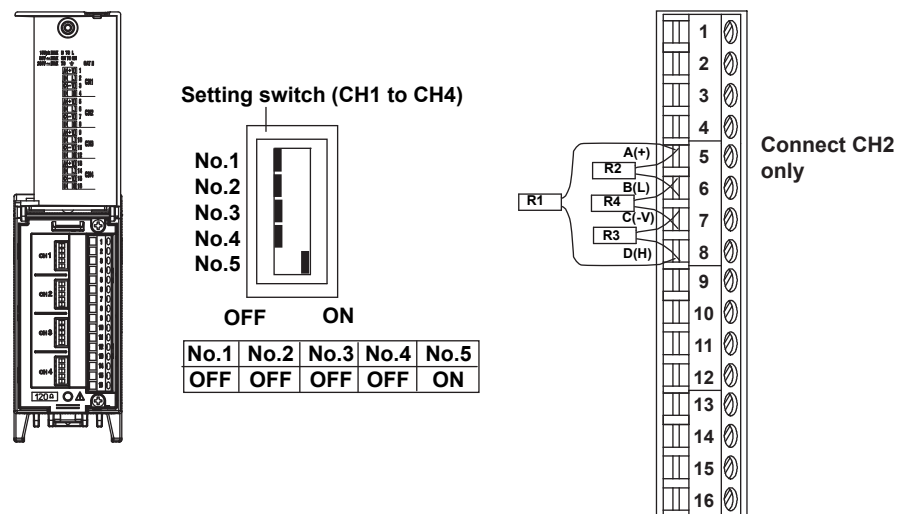

3.3 Calibration

For -NDI

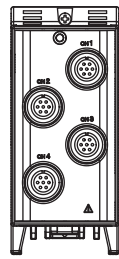

Bridge head
(701955 or 701956)

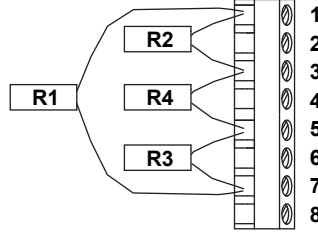

Connect CH2 only

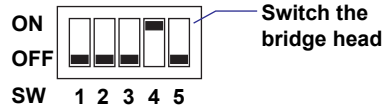

SW1	SW2	SW3	SW4	SW5
OFF	OFF	OFF	ON	OFF

- When calibrating the output range of the 8-CH, Medium-Speed Analog Output module All channels are calibrated at Zero (0 V) and Full (10 V).

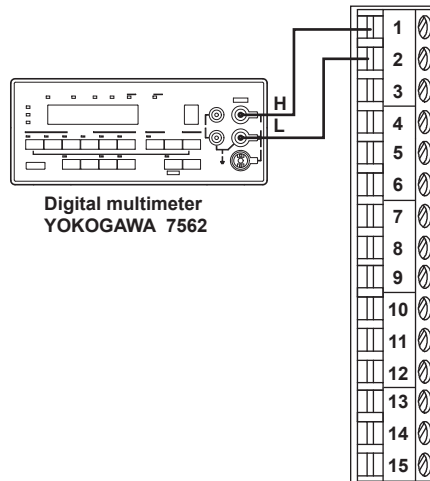
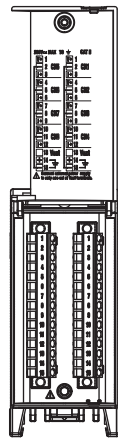

Calibration of Temperature Measurements using Thermocouples

Required Instruments

- DC voltage/current standard
Must meet the following specifications (5520A by FLUKE or equivalent)
Output accuracy: $\pm(0.005\% + 1 \mu\text{V})$ or less
- 0°C standard temperature device
Must meet the following specifications (ZC-114/ZA-10 by Coper Electronics or equivalent)
Standard temperature stability accuracy: $\pm 0.05^\circ\text{C}$ or less

Reference Junction Compensation of Thermocouple Input

The input terminal section of the input modules is normally near room temperature, so that the actual thermocouple output differs from the 0°C reference thermoelectromotive table value. Modules able to measure temperature with thermocouples can be compensated by measuring the temperature of the input terminal and adding the corresponding thermoelectromotive force to the actual thermocouple output. Therefore with the measurement terminal shorted (equivalent to an edge detection of 0°C), the measured value indicates the temperature of the input terminal.

When calibrating modules capable of temperature measurements using thermocouples, it is necessary to apply input from a DC standard voltage current generator with this compensation voltage subtracted (the electromotive force of the 0°C standard that is equivalent to the temperature of the input terminal). As in the figure, when performing reference junction compensation at 0°C using a 0°C standard temperature device, you can perform the calibration by inputting the 0°C standard electromotive force from a DC standard voltage/current generator.

Wiring Diagram

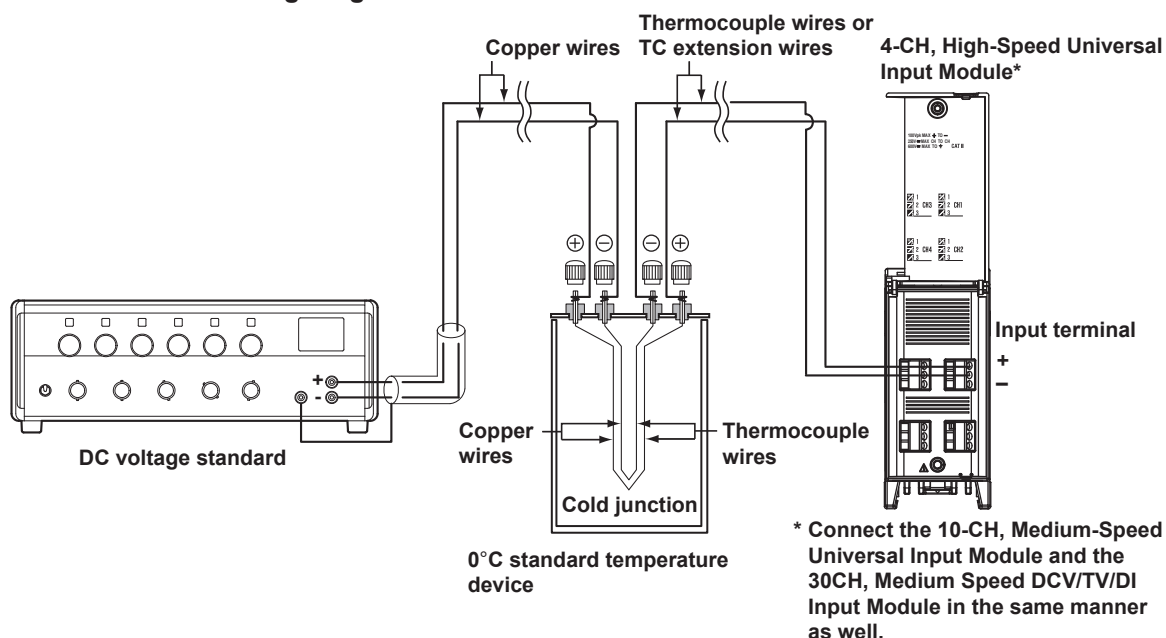

Note

- Unlike the range calibration of DC voltage or RTD, the input section cannot be adjusted for calibration of temperature measurement on the MX100 using a thermocouple. If accuracy specifications are not upheld after calibration of temperature measurement using thermocouples (see sections 4.4 through 4.6), check for input error and other factors, then contact your Yokogawa dealer.
- If errors exist in the thermocouple wires and extension wires, correct calibration is not possible. Be sure to use a calibrated thermocouple.

3.4 Maintenance of Parts

The MX100 does not have parts that need periodic replacement. However, the main module (MX100) uses expendable parts as indicated in the table below. Also, the following aluminum electrolytic capacitors are included with each input/output module. There are no replacement services for the parts listed. If you will use the instrument for an extended time, repair or repurchase the instrument by referring to this value and taking into consideration the actual usage conditions.

Part Name	Service Life	Note
Lithium battery	Approx. 10 years	When used under standard operating conditions. One battery is used.
Aluminum electrolytic capacitor	Approx. 10 years	When used under standard operating conditions.

The main module and PWM output module have a fuse. The fuse cannot be replaced by the customer. If the fuse blows, contact your nearest Yokogawa dealer for repairs.

Module	Rating
Main module power supply	Maximum rated voltage: 250 V, maximum rated current: 3.15 A
PWM module	Type: time lag (T)

3.5 MX100 Maintenance and Test Using Communication Commands

The MX100 maintenance/test function is used by a network administrator to check the communication status of the MX100.

Maintenance and test of the MX100 using communication commands can be carried out by connecting the main module and a PC using an Ethernet cable, and using a terminal emulator such as Telnet on the PC. The communication method is a command and response type (a command is sent from the PC to the MX100 and a response is returned from the MX100 to the PC). Only a single PC can connect to a single MX100.

Connecting the Main Module and the PC

See “Connection Procedure” in section 2.6.

Setting the Terminal Emulator

When carrying out maintenance and test of the MX100 using communication commands, set the terminal emulator as indicated below. Specify the IP address of the MX100 and a port number of 34317 for the destination of the terminal emulator.

- Local echo: ON
- Line feed code of the transmit data: CR+LF

List of Maintenance/Test Commands

Command Name	Function
con	Outputs TCP connection information.
eth	Outputs statistical information of Ethernet (data link layer).
help	Outputs command help.
net	Outputs other network information.
quit	Quits maintenance/test (drops the connection).

Specifications of the Maintenance/Test Port

Port number	34317/tcp
Transfer data	ASCII code
Line feed code (command)	CR+LF or LF
Line feed code (response)	CR+LF
Receive buffer	128 B
Transmit buffer	8192 B
Connection timeout	3 min. (fixed*)
Maximum number of simultaneous connections	1

* You cannot change the connection timeout setting.

con **Output connection information**

Function Outputs a list of connection information of the devices connected to the MX100.

Setting con

Example con
EA
03/01/01 00:02:45.490

Active Connections

Proto	Local Address	Foreign Address	State
TCP	10. 0. 233. 25:34316	10. 0.232.124:1382	ESTBLISHED
TCP	10. 0. 233. 25:34317	10. 0.232.124:1380	ESTBLISHED
TCP	0. 0. 0. 0:34316	0. 0. 0. 0:	0 LISTEN
TCP	0. 0. 0. 0:34317	0. 0. 0. 0:	0 LISTEN

Description Outputs a list of connections in a form enclosed by EA and EN.

Proto: Protocol used
Local Address: MX100 address and port number
Foreign Address: PC address and port number
State: Connection status (ESTBLISHED, LISTEN, CLOSE_WAIT...)
The max. number of connections that is output as connection information is 24.

eth **Output Ethernet statistical information**

Function Outputs statistical information of the packets that flowed through the MX100 interface (lo0: loopback device, lan0: network device). The output value is a summed value after the MX100 is powered up.

Setting eth

Example eth
EA
03/01/01 00:02:45.490

Ethernet Statistics

Name	In Pkt	In Err	Out Pkt	Out Err	16 Coll
lo0	0	0	0	0	0
lan0	1492	176	93	0	0

Description Outputs statistical information of the packets that flowed through the interface in a form enclosed by EA and EN.

Name: Interface name (lo: loopback, lan0: Ethernet)
In Pkt: Number of received packets
In Err: Number of packets that generated receive errors
Out Pkt: Number of transmitted packets
Out Err: Number of packets that generated transmit errors
16 Coll: Number of 16 collision occurrences

help Output command help

Function	Outputs command help. If a command name is specified as a parameter, a simple explanation of its usage is output.
Setting	help[, p1] (p1: specifies the command name for outputting help. con, eth, help, net, or quit)
Example 1	<pre> help EA 03/01/01 00:02:45.490 Command Help con - echo connection status eth - echo ethernet statistics help - echo help net - echo network statistics quit - close this connection EN </pre>
Example 2	<pre> help, help EA help[, <command name>] - echo help EN </pre>
Description	Outputs a command help or a description of how to use the command in a form enclosed by EA and EN. If an invalid command is specified, an error is output in the form "E1 Unknown command (CR+LF)."

net Output other network information

Function	Outputs settings and statistical information (APP, TCP, and DLC) specific to the MX100. The output value is a value at the time the MX100 is powered up or a summed value after the MX100 is powered up.
Setting	net
Example	<pre> net EA 03/01/01 00:02:45.490 Network Statistics APP: applalive = 180 sec TCP: keepalive = disable TCP: connects = 1 TCP: closed = 1 TCP: timeoutdrop = 0 TCP: keepdrops = 1 TCP: sndtotal = 5 TCP: sndbyte = 71 TCP: sndrexitpack = 0 TCP: sndrexitbyte = 0 TCP: rcvtotal = 10 TCP: rcvbyte = 5 DLC: 16 collisions = 0 DLC: speed = 100 Mbps EN </pre>

3.5 MX100 Maintenance and Test Using Communication Commands

Description	Outputs settings and statistical information specific to the MX100 in a form enclosed by EA and EN.
APP: applive:	APP keepalive check cycle.
TCP: keepalive:	TCP keepalive check cycle.
TCP: connects:	Total number of connections established.
TCP: closed:	Total number of dropped connections.
TCP: timeoutdrop:	Total number of dropped connections due to TCP retransmission timeout (if the transmitted packet (the unit of transmitted data) is not received, the packet is automatically retransmitted at a predetermined time interval. If the packet is not received after 14 retransmissions, timeout occurs and the connection is dropped.)
TCP: keepdrops:	Total number of dropped connections due to TCP keepalive timeout.
TCP: sndtotal:	Total number of transmitted packets.
TCP: sndbyte:	Total number of transmitted bytes.
TCP: sndremitpack:	Total number of retransmitted packets.
TCP: sndremitbyte:	Total number of retransmitted bytes.
TCP: rcvtotal:	Total number of received packets.
TCP: rcvbyte:	Total number of received bytes.
DLC: 16 collisions:	Number of collisions that occurred (A collision occurs when two or more devices on the network attempt to transmit simultaneously. The tendency for collisions to occur increases when the network is congested. 16 collisions refers to 16 consecutive collision incidents.)
DLC: speed:	Link speed

quit Quit maintenance/test (drop the connection of the device in operation)

Function	Drops the connection between the PC and the MX100.
Setting	quit
Example	quit E0
Description	After "E0" is returned, a disconnect request (FIN) is issued from the MX100.

4.1 Common Specifications

Standard operating conditions

Operating temperature range:	0 to 50°C
Operation humidity range:	20 to 80% RH for 0 to 40°C 10 to 50% RH for 40 to 50°C
Rated supply voltage:	AC power supply, 100 to 240 VAC
Supply voltage range used:	AC power supply, 90 to 250 VAC
Power supply frequency:	50 Hz \pm 2%, 60 Hz \pm 2%
Power consumption:	Up to approximately 70 VA maximum when six modules are used
Vibration:	10 to 60 Hz 0.2m/s ² or less
Shock:	Not allowed
Magnetic field:	400 A/m or less (50/60 Hz)
Position:	Upright and horizontal to ground
Structure:	Not explosion-proof
Usage location:	Indoors
Operating altitude:	2000 m or less
Installation category:	II (per CSA22.2 No. 61010-1)
Pollution degree:	2 (per IEC61010-1 CSA22.2 No. 61010-1)

Transport and Storage Conditions

Environmental conditions during transport and storage	
Storage ambient temperature:	-25 to 60°C
Storage ambient humidity:	5% to 95% RH (no condensation)
Vibration:	10 to 60 Hz 4.9m/s ² or less
Shock:	392 m/s ² or less (packaged condition)

Mechanical Specifications

External dimensions:	Approx. 442 × 131 × 159 mm (when six slots are attached)
Weight:	Approx. 4.1 kg (maximum total weight)
Installation method:	Desktop or floor, panel mount, or attached to a DIN rail
Material:	Steel plate, aluminum die-cast, molded plastic resin

Supported Standards

CSA:	Conforms to CSA22.2 No. 61010-1, overvoltage category II, pollution degree 2
UL:	Conforms to UL61010B-1 (CSA NRTL/C)
CE:	EMC directives; EN61326 Class A, EN61000-3-2, EN61000-3-3, EN55011 Class A, Group 1 Low voltage directive: EN61010-1; measurement category II, pollution degree 2
C-Tick:	Conforms to AS/NZS CISPR11 Class A Group1
Installation category II:	An index for defining transient overvoltages (includes the rated impulse withstand voltage, and applies to electrical equipment supplied with power from fixed installations such as distribution boards).
Pollution degree 2:	Indicates the degree of adherence by a solid, liquid, or vapor that reduces the withstand voltage or surface resistance (applies only to normal indoor atmospheres (with non-conductive pollution).
Measurement category II:	Applies to electrical instruments that are powered by wall outlets and other fixed installations that are wired to distribution boards, or measurements of such wires.

4.2 Main Module Specifications

Measurement

Style number:	S3
Meas. range and accuracy:	See the measurement range and accuracy given in the specifications of each input module.
Max. number of inputs:	60 (however a maximum of six modules can be controlled)
Meas. interval:	Select from 10, 50, 100, 200, 500 ms, 1, 2, 5, 10, 20, 30, or 60 s. Up to three intervals defined for the input modules can be set (multi-interval)
Synch. between modules:	Synchronized within the same sampling interval (in the same unit)
Synch. between channels:	4-CH, High-Speed Universal Module and Digital Input Module: synchronized between channels. 10-CH, Medium-Speed Universal Input Module, 30-CH, Medium-Speed DCV/TC/DI Input Module, 6-CH, Medium-Speed Four-Wire RTD Resistance Input Module, and the 4-CH, Medium-Speed Strain Input Module: due to the scanner type, not synchronized between channels
Time setting:	Configured based on the time information sent from the PC at the start of measurement
Filter function:	First-order lag filter, applicable measurement types: DC voltage, thermocouple, RTD, strain, and resistance. You can select a time constant (time until 63.2% of the output value is reached) corresponding to the sampling interval indicated in the table below. Time constant = measurement interval × N (where N = 5, 10, 20, 25, 40, 50, or 100)

Measurement Interval (s)	Selectable Time Constants (s)						
	N = 5	N = 10	N = 20	N = 25	N = 40	N = 50	N = 100
0.01	0.05	0.1	0.2	0.25	0.4	0.5	1
0.05	0.25	0.5	1	1.25	2	2.5	5
0.1	0.5	1	2	2.5	4	5	10
0.2	1	2	4	5	8	10	20
0.5	2.5	5	10	12.5	20	25	50
1	5	10	20	25	40	50	100
2	10	20	40	50	80	100	200
5	25	50	100	125	200	250	500
10	50	100	200	250	400	500	1000
20	100	200	400	500	800	1000	2000
30	150	300	600	750	1200	1500	3000
60	300	600	1200	1500	2400	3000	6000

Computation

Computation performed on the main module	
Difference comp. between channels:	Difference computation between arbitrary channels (DC voltage, thermocouple, RTD, DI, strain, resistance, and scaling)
Linear scaling:	Possible scaling ranges: DC voltage, thermocouple, RTD, DI, strain, and resistance Scaling range: -30000 to 30000 Scaling display range: -32000 to 32000 Decimal point position: Arbitrary

Linear scaling accuracy:

Linear scaling accuracy (digits)

= Measurement accuracy (digits) × expansion rate + 2 digits
(rounded up to the decimal place)

Note that the expansion rate = scaling span (digits) /
measurement span (digits)

(Ex.) Measuring range: 6 VDC (integral time of 16.67 ms or
more)

Measurement span: 1.000 to 5.000 V,

Scaling span: For a setting of 0.000 to 2.000

The measuring accuracy for 5.000 V input is as follows
according to the expression above.

$$\pm \{(0.05\% \times 5.000 \text{ V} + 2 \text{ digits}) \times (2000 / 4000) + 2 \text{ digits}\}$$

$$= \pm \{(0.0025 \text{ V} + 2 \text{ digits}) \times 0.5 + 2 \text{ digits}\}$$

$$= \pm 4.25$$

$$\approx 5 \text{ digits (rounded up to the decimal place)}$$

Thus the measuring accuracy when scaling = ± 5 digits

Remote RJC

When the item to be measured is located at a great distance, you can setup relay terminals near the item, measure between the relay terminal and the input terminal of the input module (reference channel) using thermocouples, and use the resultant value as the reference junction compensation of the temperature measurement. However, the same thermocouple type is used for reference channels and measured channels.

Alarms

Alarms available on the main module (active even when communication is disconnected)^{*1}

Alarm types: Upper limit, lower limit, differential upper limit, and differential lower limit

Number of settings: 4 levels per channel

Alarm setting range: DCV, thermocouple, RTD, DI, strain, resistance, and scaling

Hysteresis: Sets the hysteresis width of the alarm occurrence/release.

No. of alarm outputs: 10 to 60 (10 points per DO module)

Output mode: Alarm, manual^{*2}, Fail, Error

^{*1} When connected to PC software, the upper/lower limit alarm and upper/lower limit on rate-of-change alarms of computation channels can be performed.

^{*2} At least 100 ms is required for the response time to detect changes in output.

The “and” logic cannot be used with the MX100 Standard Software.

Data Storage

Saves measured data to the CF card on the main module if communication is disconnected while recording measured data on the PC.

Supported external media:

CF card (up to 2 GB)

Save start condition: When the timeout time elapses after the communication is disconnected during recording of measured data on the PC (the timeout time refers to the time from the point when the communication between the PC and MX100 is disconnected and acquisition of measured data is stopped to the point when data storage to the CF card starts; the setting is 60 s)

4.2 Main Module Specifications

Save mode:	<p>The following two modes are available for the save operation when communication is disconnected.</p> <p>Rotary: In this mode, the most recently measured data is retained. Saving is carried out while securing free space. When new files are created, data files are saved while up to 30 files are deleted in order starting from the file with the oldest time stamp in the root directory (subdirectories are not applicable). Deleted data are not necessarily MX100 files. If free space cannot be secured, or when securing of free space takes extended time, an error is indicated on the 7-segment LED (see “Media-Related Errors” in section 3.1).</p> <p>FullStop: In this mode, the oldest measured data is retained. Stops saving when there is no more free space on the CF card.</p>
Status detection:	<p>There are two types of statuses.</p> <p>CF card inserted: Yes/No, CF card usable: Yes/No</p> <ul style="list-style-type: none">• When the CF card is not inserted: Inserted: No, Use: No• When the CF card is inserted: Inserted: Yes, Use: Yes• When an error occurs*: Inserted: Yes, Use: No• After pressing the access stop switch **: Inserted: Yes, Use: No <p>* If a media-related error occurs and the card can no longer be used, further data storage is stopped. To clear this condition, press the access stop switch (see section 2.8) and eject the CF card. Check the contents of the CF card and log file on the PC, and insert the CF card again.</p> <p>** If you press the access stop switch and the card can no longer be used, further data storage (excluding the creation of a log file) is stopped. The status is automatically cleared the next time recording is started.</p>
Timeout time:	<p>Initial value 60 s (settings can be changed using the MX100/DARWIN API (sold separately))</p> <p>To save the data so that no dropouts occur, the timeout time* must be set appropriately. If the setting is inappropriate, an error is indicated on the 7-segment LED (see “Media-Related Errors” in section 3.1), and the data storage is not performed.</p> <p>* <u>Timeout time setting (guideline)</u> Timeout time [s] < 2 [MB]/(data size per second) – 20 [s] Data size per second is the total for all measurement intervals. Data size per second for each measurement interval = Time 16 [bytes] + (measured value 4 [bytes] × the number of channels)/ measurement interval [s] (Ex.) Measurement interval: 10 ms (1 type), no. of channels: 60 Data size = (16 bytes + (4 bytes × 60))/0.01 [s] = 25600 [bytes] Thus, the timeout time is (2 [MB] / 25600 [bytes]) – 20 [s] = 61.9 [s] > <u>60 [s]</u></p>
Saved channels:	Measurement channels monitored on the PC (not channels set for recording)
Save interval:	60 s (automatically saves using the timeout time as the save interval)
File size:	Approx. 5 MB/file (for a file with minimum measurement interval)
Data size per channel:	4 bytes

File name: MDDIXXXX.MXD
 M: Month when saving started (local time), 1-9, X (October), Y (November), Z (December)
 DD: Data when saving started (local time), 1-31
 I: Measurement interval number, 0-2, up to three types in order from the shortest measurement interval (if the measurement (monitoring) interval is the same even when the measurement group is different, the data are placed in a single file under the same measurement interval number.)
 XXXX: Sequence number 0000-9999
 .MXD: Extension (upper-case characters) specific to the MX100

Guarantee of data during power failure:
 Writing up to immediately before the power failure is guaranteed (saving (backup) does not continue after the power failure recovers).

Equation for calculating the size of the saved file:

Size of the saved file (bytes) = header size^{*1} + (data size^{*2} x write count^{*3})

*1 Header size = file information + channel information x number of saved channels

File information: S1, S2: 416 [bytes], S3: 424 [bytes]

Channel Information: S1: 176 [bytes], S2: 184 [bytes], S3: 232 [bytes]

*2 Data size = 4 [bytes] x the number of saved channels x sample count
 Sample count = Save interval [s]/measurement interval [s]

*3 Write count = ((5 [MB] - header size)/(data size)) or less (truncated to an integer)

(Ex.) Measurement interval: 10 ms, number of measurement channels: 24 ch, style number S3

Header size = 424 [bytes] + 232 [bytes] x 24 = 5992 [bytes]

Data size = 4 [bytes] x 24 x (60 [s]/0.01 [s]) = 576000 [bytes]

Write count = (5 x 1024 x 1024 - 5992 [bytes])/576000 [bytes] = 9.1 (= approx. 9)

Thus, the file size is:

(5992 [bytes]) + (576000 [bytes] x 9) = 5189992 [bytes]

Guideline of the sample time for the different CF card sizes (when one type of measurement interval is used):

Number of Saved CHs	Measurement Interval	Capacity of the CF card						
		32 MB (6 files)	64 MB (12 files)	128 MB (34 files)	256 MB (98 files)	512 MB (198 files)	1 GB (196 files)	2 GB (390 files)
10 CHs	10 ms	2.1 hours	4.2 hours	8.7 hours	17.5 hours	35.3 hours	2.9 days	5.9 days
	50 ms	10.9 hours	21.8 hours	1.8 days	3.6 days	7.3 days	14 days	29 days
	100 ms	21.8 hours	1.8 days	3.6 days	7.2 days	14 days	29 days	59 days
	200 ms	1.8 days	3.6 days	7.2 days	14 days	29 days	59 days	118 days
	500 ms	4.5 days	9 days	18 days	36 days	73 days	147 days	295 days
	1 s	9 days	18 days	36 days	72 days	147 days	295 days	591 days
24 CHs	2 s	18 days	36 days	72 days	145 days	294 days	591 days	1182 days
	10 ms	54 min.	1.8 hours	3.6 hours	7.3 hours	14.7 hours	29.5 hours	2.4 days
	50 ms	4.5 hours	9 hours	18 hours	1.5 days	3 days	6.1 days	12 days
	100 ms	9 hours	18 hours	1.5 days	3 days	6.1 days	12 days	24 days
	200 ms	18.1 hours	1.5 days	3 days	6.1 days	12 days	24 days	49 days
	500 ms	1.8 days	3.7 days	7.5 days	15 days	30 days	61 days	122 days
60 CHs	1 s	3.7 days	7.5 days	15 days	30 days	61 days	123 days	246 days
	2 s	7.5 days	15 days	30 days	60 days	122 days	246 days	492 days
	10 ms	21 min.	42 min.	1.4 hours	2.9 hours	5.8 hours	11.7 hours	23.4 hours
	50 ms	1.8 hours	3.6 hours	7.2 hours	14.7 hours	29.4 hours	2.4 days	4.9 days
	100 ms	3.6 hours	7.2 hours	14.4 hours	29.4 hours	2.4 days	4.9 days	9.8 days
	200 ms	7.2 hours	14.4 hours	28.8 hours	2.4 days	4.9 days	9.8 days	19 days
60 CHs	500 ms	18.1 hours	1.5 days	3 days	6 days	12 days	24 days	49 days
	1 s	1.5 days	3 days	6 days	12 days	24 days	49 days	98 days
	2 s	3 days	6 days	12 days	24 days	49 days	98 days	196 days

4.2 Main Module Specifications

Display

LED: Ethernet communication status (LINK, ACT)
Two-digit 7-segment LED: Status of the MX100 (unit number, operation status, and error indication)

Communications

Interface: Ethernet (10BASE-T/100BASE-TX)
Connector type: RJ-45
Protocol: TCP, IP, UDP, ARP, and ICMP
Transmission function: Transmits measured values and settings
Reception function: Receives settings
TCP connection timeout: If there is no packet exchange for three minutes or more (not configurable) when using TCP, a connection timeout occurs. This mainly occurs when using the MX100/DARWIN API (sold separately).

Other Functions

Time function: Normally operates using the PC clock
Backup function available (records the times of the data using time stamps of the main module when communication is disconnected)
Internal clock accuracy: ± 100 ppm
Dip switches: Used to initialize settings, etc. (number of switches: 8)
Access stop switch (CF card control switch):
Closes the file to which data is being written on the CF card
Saves the log file

General Specifications

Power consumption: Approximately 8 W
Insulation resistance: 20 M Ω or more at 500 VDC between the power supply terminal and earth terminal
Withstand voltage: 1500 VAC (50/60 Hz) for one minute between the power supply terminal and earth terminal
External dimensions: Approximately 92 (W) \times 131 (H) \times 137 (D) mm
Weight: Approximately 0.85 kg

External Dimensions

Unit: mm

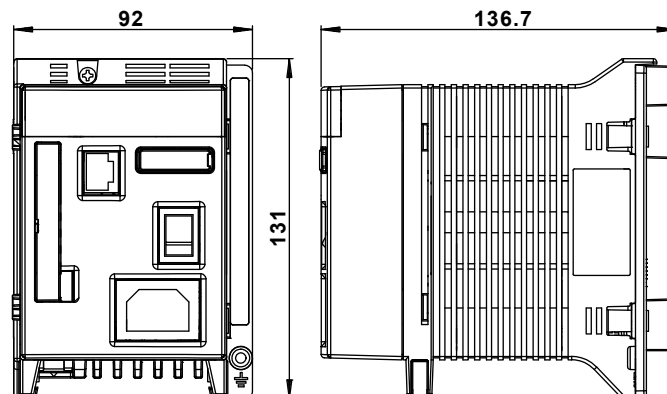

If not specified, the tolerance is $\pm 3\%$. However, in cases of less than 10 mm, the tolerance is ± 0.3 mm.

4.3 Base Plate Specifications

Number of main modules that can be attached:

1 (always attached)

Number of input/output modules that can be attached:

1 to 6* (specified by the suffix code)

* One 30-CH, Medium-Speed DCV/TC/RTD Input Module uses three modules worth of space.

External dimensions: Approximately 118-408 (W) × 75 (H) × 35 (D) mm

Weight: Approximately 0.37 kg (1 main module, for connecting six input/output modules)

External Dimensions

Unit: mm

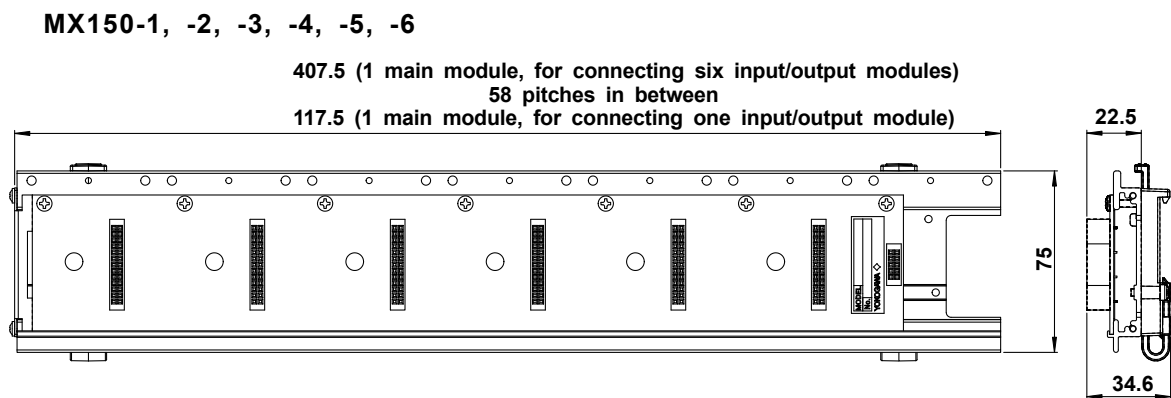

If not specified, the tolerance is $\pm 3\%$. However, in cases of less than 10 mm, the tolerance is ± 0.3 mm.

4.4 4-CH, High-Speed Universal Input Module Specifications

Style number: S1
 Type of measurement: DC voltage, thermocouple, 3-wire RTD, DI (LEVEL, non-voltage contact)
 Number of inputs: 4
 Input method: Floating unbalanced input, insulation between channels
 A/D resolution: 16 bits ($\pm 20000/\pm 6000/0$ to 60000)
 Measurement range and accuracy:

The accuracy applies to standard operating conditions:
 Ambient temp: $23 \pm 2^\circ\text{C}$, ambient humidity: $55 \pm 10\%$ RH, supply voltage: 90 to 250 VAC, power frequency: 50/60 Hz $\pm 1\%$, warm-up time: at least 30 minutes, without adverse conditions such as vibrations.

Input	Measurement Range Type	Rated Measurement Range	Measurement Accuracy		Highest Resolution (1 Digit)
			Integration Time: 16.67 ms or More	Integration Time: 1.67 ms	
DC voltage	20 mV	-20.000 to 20.000 mV	$\pm(0.05\%$ of rdg + 5 digits)	$\pm(0.1\%$ of rdg + 25 digits)	1 μV
	60 mV	-60.00 to 60.00 mV	$\pm(0.05\%$ of rdg + 2 digits)	$\pm(0.1\%$ of rdg + 10 digits)	10 μV
	200 mV	-200.00 to 200.00 mV			
	2 V	-2.0000 to 2.0000 V	$\pm(0.05\%$ of rdg + 5 digits)	$\pm(0.1\%$ of rdg + 10 digits)	100 μV
	6 V	-6.000 to 6.000 V	$\pm(0.05\%$ of rdg + 2 digits)		1 mV
	20 V	-20.000 to 20.000 V			10 mV
100 V	-100.00 to 100.00 V				
Thermocouple (excludes RJC accuracy, when burnout is OFF)	R ^{*1}	0.0 to 1760.0°C	$\pm(0.05\%$ of rdg + 1°C) Except 0 to 100°C: $\pm 3.7^\circ\text{C}$, 100 to 300°C: $\pm 1.5^\circ\text{C}$ for R and S; 400 to 600°C: $\pm 2^\circ\text{C}$, less than 400°C: not guaranteed for B	$\pm(0.1\%$ of rdg + 4°C) Except 0 to 100°C: $\pm 10^\circ\text{C}$, 100 to 300°C: $\pm 5^\circ\text{C}$ for R and S; 400 to 600°C: $\pm 7^\circ\text{C}$, less than 400°C: not guaranteed for B	0.1°C
	S ^{*1}				
	B ^{*1}	0.0 to 1820.0°C	$\pm(0.05\%$ of rdg + 0.7°C) Except -200°C to -100°C: $\pm(0.05\%$ of rdg + 1°C)	$\pm(0.1\%$ of rdg + 3.5°C) Except -200°C to -100°C: $\pm(0.1\%$ of rdg + 6°C)	
	K ^{*1}	-200.0 to 1370.0°C			
	E ^{*1}	-200.0 to 800.0°C	$\pm(0.05\%$ of rdg + 0.5°C) Except -200°C to -100°C: $\pm(0.05\%$ of rdg + 0.7°C) for J and L	$\pm(0.1\%$ of rdg + 2.5°C) Except -200°C to -100°C: $\pm(0.1\%$ of rdg + 5°C)	
	J ^{*1}	-200.0 to 1100.0°C			
	T ^{*1}	-200.0 to 400.0°C			
	L ^{*2}	-200.0 to 900.0°C	$\pm(0.05\%$ of rdg + 0.7°C)	$\pm(0.1\%$ of rdg + 3.5°C)	
	U	-200.0 to 400.0°C			
	N ^{*3}	0.0 to 1300.0°C	$\pm(0.05\%$ of rdg + 1°C)	$\pm(0.1\%$ of rdg + 7°C)	
	W ^{*4}	0.0 to 2315.0°C	$\pm(0.05\%$ of rdg + 0.7K)	$\pm(0.1\%$ of rdg + 3.5K)	
KPvsAu7Fe	0.0 to 300.0K	$\pm(0.05\%$ of rdg + 0.3°C)	$\pm(0.1\%$ of rdg + 1.5°C)	0.1°C	
RTD (Measurement current: 1 mA)	Pt100 ^{*5}	-200.0 to 600.0°C	$\pm(0.05\%$ of rdg + 0.3°C)	$\pm(0.1\%$ of rdg + 1.5°C)	
	JPt100 ^{*5}	-200.0 to 550.0°C			
	Pt100 (high res.)	-140.00 to 150.00°C	$\pm(0.05\%$ of rdg + 0.3°C)	$\pm(0.1\%$ of rdg + 1.5°C)	0.01°C
	JPt100 (high res.)	-140.00 to 150.00°C			
	Ni100 SAMA ^{*6}	-200.0 to 250.0°C	$\pm(0.05\%$ of rdg + 0.3°C)	$\pm(0.1\%$ of rdg + 1.5°C)	0.1°C
	Ni100 DIN ^{*6}	-60.0 to 180.0°C			
	Ni120 ^{*7}	-70.0 to 200.0°C			
RTD (Measurement current: 2 mA)	Pt100 ^{*5}	-200.0 to 250.0°C	$\pm(0.05\%$ of rdg + 0.3°C)	$\pm(0.1\%$ of rdg + 1.5°C)	0.1°C
	JPt100 ^{*5}	-200.0 to 250.0°C			
	Pt100 (high res.)	-140.00 to 150.00°C	$\pm(0.05\%$ of rdg + 0.3°C)	$\pm(0.1\%$ of rdg + 1.5°C)	0.01°C
	JPt100 (high res.)	-140.00 to 150.00°C			
	Pt50 ^{*5}	-200.0 to 550.0°C	$\pm(0.05\%$ of rdg + 0.7°C)	$\pm(0.2\%$ of rdg + 2.5°C)	0.1°C
	Cu10 GE ^{*8}	-200.0 to 300.0°C			
	Cu10 L&N ^{*8}	-200.0 to 300.0°C			
	Cu10 WEED ^{*8}	-200.0 to 300.0°C			
	Cu10 BAILEY ^{*8}	-200.0 to 300.0°C	$\pm(0.05\%$ of rdg + 0.3K)	$\pm(0.1\%$ of rdg + 1.5K)	0.1K
	J263B	0.0 to 300.0K			
DI	Level	Vth = 2.4 V	Threshold level accuracy: ± 0.1 V		
	Contact input	ON for 100 Ω or less, OFF for 10 k Ω or more ^{*9}			

*1 R, S, B, K, E, J, T: ANSI, IEC 584, DIN IEC 584, JIS C 1602-1995

*2 L: Fe-CuNi, DIN43710/U: Cu-CuNi, DIN 43710

*3 N: Nicrosil-Nisil, IEC 584, DIN IEC 584

*4 W: W-5% RE/W-26% Re (Hoskins Mfg Co)

*5 Pt50: JIS C 1604-1981, JIS C 1606-1986/Pt100: JIS C 1604-1989, JIS C 1606-1989, IEC 751, DIN IEC 751/JPt100: JIS C 1604-1981, JIS C 1606-1989

*6 SAMA/DIN

*7 McGRRAW EDISON COMPANY

*8 Guaranteed accuracy range Cu10 GE: -84.4 to 170.0°C/Cu10 L&N: -75.0 to 150.0°C/Cu10 WEED: -20.0 to 250.0°C/Cu10 BAILEY: -20.0 to 250.0°C

*9 Measured using a measurement current of approximately 1 mA at 1-V range. Threshold level is approximately 0.8 V.

4.4 4-CH, High-Speed Universal Input Module Specifications

The inputs indicated below can be used on MXLOGGER or the MX100/DARWIN API (software sold separately).

Input	Measurement Range Type	Rated Measurement Range	Measurement Accuracy		Highest Resolution (1 Digit)
			Integration Time: 16.67 ms or More	Integration Time: 1.67 ms	
DC voltage	60 mV (high res.)	0.000 to 60.000 mV	$\pm(0.05\%$ of rdg + 20 digits)	$\pm(0.1\%$ of rdg + 100 digits)	1 μ V
	1 V	-1.0000 to 1.0000 V	$\pm(0.05\%$ of rdg + 2 digits)	$\pm(0.1\%$ of rdg + 10 digits)	100 μ V
	6 V (high res.)	0.0000 to 6.0000 V	$\pm(0.05\%$ of rdg + 20 digits)	$\pm(0.1\%$ of rdg + 100 digits)	100 μ V
Thermocouple (excludes RJC accuracy, when burnout is OFF)	PLATINEL	0.0 to 1400.0°C	$\pm(0.05\%$ of rdg + 1°C)	$\pm(0.1\%$ of rdg + 4°C)	0.1°C
	PR40-20	0.0 to 1900.0°C	$\pm(0.05\%$ of rdg + 2.5°C) Except 300 to 700°C: $\pm 6^\circ\text{C}$ less than 300°C: not guaranteed	$\pm(0.1\%$ of rdg + 12°C) Except 300 to 700°C: $\pm 25^\circ\text{C}$ less than 300°C: not guaranteed	
	NiNiMo	0.0 to 1310.0°C	$\pm(0.05\%$ of rdg + 0.7°C)	$\pm(0.1\%$ of rdg + 2.7°C)	
	WRe3-25	0.0 to 2400.0°C	$\pm(0.05\%$ of rdg + 2°C) Except 0 to 200°C: $\pm 2.5^\circ\text{C}$ 2000°C or higher: $\pm(0.05\%$ of rdg + 4°C)	$\pm(0.1\%$ of rdg + 7°C) Except 0 to 200°C: $\pm 12^\circ\text{C}$ 2000°C or higher: $\pm(0.1\%$ of rdg + 11°C)	
	W/WRe26	0.0 to 2400.0°C	$\pm(0.05\%$ of rdg + 2°C) Except 100 to 300°C: $\pm 4^\circ\text{C}$ less than 100°C: not guaranteed	$\pm(0.1\%$ of rdg + 8.5°C) Except 100 to 300°C: $\pm 12^\circ\text{C}$ less than 100°C: not guaranteed	
	N (AWG14)	0.0 to 1300.0°C	$\pm(0.05\%$ of rdg + 0.7°C)	$\pm(0.1\%$ of rdg + 3.5°C)	
	XK GOST	-200.0 to 600.0°C	$\pm(0.05\%$ of rdg + 0.5°C) Except -200 to 0°C: $\pm(0.2\%$ of rdg + 0.7°C)	$\pm(0.1\%$ of rdg + 2.5°C) Except -200 to 0°C: $\pm(1\%$ of rdg + 2.5°C)	
RTD (Measurement current: 1 mA)	Pt100 (noise resistance)	-200.0 to 600.0°C	$\pm(0.05\%$ of rdg + 0.3°C)	$\pm(0.1\%$ of rdg + 2.5°C)	0.1°C
	JPt100 (noise resistance)	-200.0 to 550.0°C			
	Pt100 GOST	-200.0 to 600.0°C	$\pm(0.05\%$ of rdg + 0.3°C)	$\pm(0.1\%$ of rdg + 1.5°C)	
RTD (Measurement current: 2 mA)	Cu10 at 20°C alpha = 0.00392	-200.0 to 300.0°C	$\pm(0.1\%$ of rdg + 0.7°C)	$\pm(0.2\%$ of rdg + 2.5°C)	0.1°C
	Cu10 at 20°C alpha = 0.00393	-200.0 to 300.0°C			
	Cu25 at 0°C alpha = 0.00425	-200.0 to 300.0°C	$\pm(0.1\%$ of rdg + 0.5°C)	$\pm(0.2\%$ of rdg + 2°C)	
	Cu53 at 0°C alpha = 0.00426035	-50.0 to 150.0°C	$\pm(0.05\%$ of rdg + 0.3°C)	$\pm(0.1\%$ of rdg + 1.5°C)	
	Cu100 at 0°C alpha = 0.00425	-50.0 to 150.0°C			
	Pt25 (JPt100 \times 1/4)	-200.0 to 550.0°C	$\pm(0.1\%$ of rdg + 0.5°C)	$\pm(0.2\%$ of rdg + 2°C)	
	Cu10 GE (high resolution)	-200.0 to 300.0°C	$\pm(0.1\%$ of rdg + 0.7°C)	$\pm(0.2\%$ of rdg + 2.5°C)	
	Cu10 L&N (high resolution)	-200.0 to 300.0°C			
	Cu10 WEED (high resolution)	-200.0 to 300.0°C			
	Cu10 BAILEY (high resolution)	-200.0 to 300.0°C			
	Pt100 (noise resistance)	-200.0 to 250.0°C	$\pm(0.05\%$ of rdg + 0.3°C)	$\pm(0.1\%$ of rdg + 1.5°C)	
	JPt100 (noise resistance)	-200.0 to 550.0°C			
	Cu100 GOST	-200.0 to 200.0°C	$\pm(0.05\%$ of rdg + 0.3°C)	$\pm(0.1\%$ of rdg + 1.5°C)	
	Cu50 GOST	-200.0 to 200.0°C	$\pm(0.1\%$ of rdg + 0.7°C)	$\pm(0.2\%$ of rdg + 2.5°C)	
Cu10 GOST	-200.0 to 200.0°C				

Measurement interval, integration time, and filter:

Measurement Interval	Integration Time	Filter	Rejected Noise and Notes
10 ms	1.67 ms	Rectangular	600 Hz and its integer multiples*
50 ms	16.67 ms		60 Hz and its integer multiples
	20 ms		50 Hz and its integer multiples
	Auto		Automatically detects the power supply frequency and set 16.67 or 20 ms
100, 200 ms	36.67 ms	Trapezoidal	50 Hz or 60 Hz and their integer multiples
500 ms	100 ms	Rectangular	10 Hz and its integer multiples
1, 2, 5, 10, 20, 30, 60 s	200 ms	Cos	Fc = 5-Hz low-pass filter

* Since the power supply frequency noise is not rejected, the measured values may fluctuate especially with temperature measurement. In such cases, set the measurement interval to 50 ms or higher.

Reference junction compensation:

Switch between external and internal on each channel, remote RJC function available

4.4 4-CH, High-Speed Universal Input Module Specifications

Reference junction compensation accuracy:	When measuring temperature greater than or equal to 0°C and when the temperature of the input terminal is balanced Type R, S, W: ±1°C Type K, J, E, T, N, L, U, XK GOST: ±0.5°C Type N(AWG14), PLATINEL, NiNiMo, WRe3-25, W/WRe26: ±1°C Note: The internal reference junction compensation is fixed to 0°C for type B and PR40-20
Maximum input voltage:	DC voltage at 1-V range or less, thermocouple, RTD, and DI (contact): ±10 VDC (continuous) Other measurement ranges: ±120 VDC (continuous)
Normal-mode voltage:	DC voltage, thermocouple, DI (LEVEL): 1.2 times the range rating or less (50/60 Hz, peak value including the signal component) RTD 100 Ω: 50 mV peak RTD 10 Ω, 25 Ω, 50 Ω: 10 mV peak
Normal-mode rejection ratio:	For integration time of 16.67 ms or more: 40 dB or more (50/60 Hz ±0.1%) For integration time of 1.67 ms: 50/60 Hz is not rejected The RTD and resistance ranges indicates the voltage conversion value when current flows.
Common-mode voltage:	600 VAC rms (50/60 Hz), reinforced (double) insulation
Common-mode rejection ratio:	The RTD and resistance ranges indicate the voltage conversion value when measurement current applied. For integration time is 16.67 ms or more: 120 dB or more For integration time is 1.67 ms or more: 80 dB or more (50/60 Hz ±0.1%, 500 Ω unbalanced, between the minus terminal and ground)
Common-mode voltage between channels:	250 VACrms (50/60 Hz), reinforced (double) insulation
Noise rejection:	Rejection by the integrating A/D converter and the use of low pass filters
Input resistance:	DC voltage at 1 V range or less, thermocouple range: 10 MΩ or more DC voltage at 2 V range or more: Approx. 1 MΩ Measurement stopped: Approx. 1 MΩ
Insulation resistance:	20 MΩ or more (500 VDC) between the input and earth
Input bias current:	10 nA or less (except for burnout setting)
Withstand voltage:	2300 VAC (50/60 Hz) for one minute between input terminals 3700 VAC (50/60 Hz) for one minute between the input terminal and earth terminal
Input signal source resistance:	DC voltage and thermocouple: 2 kΩ or less RTD 50 Ω and 100 Ω systems: 10 Ω or less per cable RTD 10 Ω and 25 Ω systems: 1 Ω or less per cable
Thermocouple burnout:	Superposed electric current system, detection within the thermocouple range (detection ON/OFF possible) Up/Down setting is possible, current approximately 100 nA 2 kΩ or less: normal, 10 MΩ or more: line broken Effect on measurement accuracy: ±15 μV or less (excluding the effect of signal source resistance)
Parallel capacity during RTD:	0.01 μF or less

4.4 4-CH, High-Speed Universal Input Module Specifications

Power consumption:	Approximately 3 W
External dimensions:	Approximately 57 (W) × 131 (H) × 151 (D) mm (including the terminal cover)
Weight:	Approximately 0.5 kg
Terminal type:	Clamp, detachable on each channel
Applicable wire size:	0.2 to 2.5 mm ² (AWG24 to 12)

Effects of Operating Conditions

The specifications below apply when the integration time is 16.67 ms or more.

Warm-up time: At least 30 minutes after power-up

Effects of ambient temperature:

The effect received by changes in 10°C increments of the ambient temperature is: $\pm(0.05\%$ of rdg + 0.05% of range) or less

However, Cu10Ω: $\pm(0.2\%$ of range + 1 digit)

Effects of power fluctuation:

Meets the accuracy specifications for AC power supply in the range 90 to 132 V and 180 to 250 V

Effects of magnetic field:

The fluctuation in external magnetic fields for AC (50/60 Hz) 400 A/m is $\pm(0.1\%$ of rdg + 10 digits) or less

Effects from the signal source resistance: Effects on DC voltage and thermocouple from a fluctuation of 1 kΩ in the signal source resistance

DC voltage: 1 V range or less $\pm 10\mu\text{V}$ or less

2 V range or higher $\pm 0.15\%$ of rdg or less

Thermocouple: $\pm 10\mu\text{V}$ or less

However, $\pm 150\mu\text{V}$ or less for burnout setting.

RTD: Fluctuation due to 10 Ω change per cable (same resistance for the three wires); 100 Ω system: $\pm 0.1^\circ\text{C}$ or less, systems other than 100 Ω: $\pm 1.0^\circ\text{C}$ or less. Fluctuation due to a difference in the resistance between lead wires of 40 mΩ (maximum difference among three wires) is approximately 0.1°C (for Pt100)

Effect of position: Horizontal with the feet at the bottom is the rule.

Effects of vibration: The fluctuation that results by applying a sinusoidal vibration along all three axis at a frequency between 10 to 60 Hz and an acceleration of 0.2 m/s² is $\pm(0.1\%$ of rdg + 1 digit) or less

External Dimensions

Unit: mm

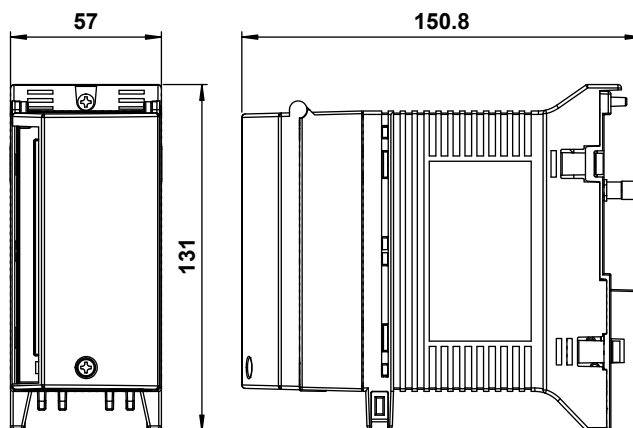

If not specified, the tolerance is $\pm 3\%$. However, in cases of less than 10 mm, the tolerance is ± 0.3 mm.

4.5 10-CH, Medium-Speed Universal Input Module Specifications

Style number:	S1
Type of measurement:	DC voltage, thermocouple, 3-wire RTD, DI (LEVEL, non-voltage contact)
Number of inputs:	10
Input method:	Floating unbalanced input, insulation between channels (b terminal common for RTD)
A/D resolution:	16 bits ($\pm 20000/\pm 6000/0$ to 60000)
Measurement range and accuracy:	

The accuracy applies to standard operating conditions:
 Ambient temp: 23 $\pm 2^\circ\text{C}$, ambient humidity: 55 $\pm 10\%$ RH, supply voltage: 90 to 250 VAC, power frequency: 50/60 Hz $\pm 1\%$, warm-up time: at least 30 minutes, without adverse conditions such as vibrations.

Input	Measurement Range Type	Rated Measurement Range	Measurement Accuracy		Highest Resolution (1 Digit)
			Integration Time: 16.67 ms or More	Integration Time: 1.67 ms	
DC voltage	20 mV	-20.000 to 20.000 mV	$\pm(0.05\%$ of rdg + 5 digits)	$\pm(0.1\%$ of rdg + 25 digits)	1 μV
	60 mV	-60.00 to 60.00 mV	$\pm(0.05\%$ of rdg + 2 digits)	$\pm(0.1\%$ of rdg + 10 digits)	10 μV
	200 mV	-200.00 to 200.00 mV			
	2 V	-2.0000 to 2.0000 V	$\pm(0.05\%$ of rdg + 5 digits)		100 μV
	6 V	-6.000 to 6.000 V	$\pm(0.05\%$ of rdg + 2 digits)		1 mV
	20 V	-20.000 to 20.000 V			
100 V	-100.00 to 100.00 V	10 mV			
Thermocouple (excludes RJC accuracy, when burnout is OFF)	R ^{*1}	0.0 to 1760.0 $^\circ\text{C}$	$\pm(0.05\%$ of rdg + 1 $^\circ\text{C}$) Except 0 to 100 $^\circ\text{C}$: $\pm 3.7^\circ\text{C}$, 100 to 300 $^\circ\text{C}$: $\pm 1.5^\circ\text{C}$ for R and S; 400 to 600 $^\circ\text{C}$: $\pm 2^\circ\text{C}$, less than 400 $^\circ\text{C}$: not guaranteed for B	$\pm(0.1\%$ of rdg + 4 $^\circ\text{C}$) Except 0 to 100 $^\circ\text{C}$: $\pm 10^\circ\text{C}$, 100 to 300 $^\circ\text{C}$: $\pm 5^\circ\text{C}$ for R and S; 400 to 600 $^\circ\text{C}$: $\pm 7^\circ\text{C}$, less than 400 $^\circ\text{C}$: not guaranteed for B	0.1 $^\circ\text{C}$
	S ^{*1}				
	B ^{*1}				
	K ^{*1}	-200.0 to 1370.0 $^\circ\text{C}$	$\pm(0.05\%$ of rdg + 0.7 $^\circ\text{C}$) Except -200 $^\circ\text{C}$ to -100 $^\circ\text{C}$: $\pm(0.05\%$ of rdg + 1 $^\circ\text{C}$)	$\pm(0.1\%$ of rdg + 3.5 $^\circ\text{C}$) Except -200 $^\circ\text{C}$ to -100 $^\circ\text{C}$: $\pm(0.1\%$ of rdg + 6 $^\circ\text{C}$)	
	E ^{*1}	-200.0 to 800.0 $^\circ\text{C}$	$\pm(0.05\%$ of rdg + 0.5 $^\circ\text{C}$) Except -200 $^\circ\text{C}$ to -100 $^\circ\text{C}$: $\pm(0.05\%$ of rdg + 0.7 $^\circ\text{C}$) for J and L	$\pm(0.1\%$ of rdg + 2.5 $^\circ\text{C}$) Except -200 $^\circ\text{C}$ to -100 $^\circ\text{C}$: $\pm(0.1\%$ of rdg + 5 $^\circ\text{C}$)	
	J ^{*1}	-200.0 to 1100.0 $^\circ\text{C}$			
	T ^{*1}	-200.0 to 400.0 $^\circ\text{C}$			
	L ^{*2}	-200.0 to 900.0 $^\circ\text{C}$			
	U	-200.0 to 400.0 $^\circ\text{C}$	$\pm(0.05\%$ of rdg + 0.7 $^\circ\text{C}$)	$\pm(0.1\%$ of rdg + 3.5 $^\circ\text{C}$)	
	N ^{*3}	0.0 to 1300.0 $^\circ\text{C}$			
	W ^{*4}	0.0 to 2315.0 $^\circ\text{C}$	$\pm(0.05\%$ of rdg + 1 $^\circ\text{C}$)	$\pm(0.1\%$ of rdg + 7 $^\circ\text{C}$)	
KPvsAu7Fe	0.0 to 300.0K	$\pm(0.05\%$ of rdg + 0.7K)	$\pm(0.1\%$ of rdg + 3.5K)	0.1K	
RTD (Measurement current: 1 mA)	Pt100 ^{*5}	-200.0 to 600.0 $^\circ\text{C}$	$\pm(0.05\%$ of rdg + 0.3 $^\circ\text{C}$)	$\pm(0.1\%$ of rdg + 1.5 $^\circ\text{C}$)	0.1 $^\circ\text{C}$
	JPt100 ^{*5}	-200.0 to 550.0 $^\circ\text{C}$			
	Pt100 (high res.)	-140.00 to 150.00 $^\circ\text{C}$	$\pm(0.05\%$ of rdg + 0.3 $^\circ\text{C}$)	$\pm(0.1\%$ of rdg + 1.5 $^\circ\text{C}$)	0.01 $^\circ\text{C}$
	JPt100 (high res.)	-140.00 to 150.00 $^\circ\text{C}$			
	Ni100 SAMA ^{*6}	-200.0 to 250.0 $^\circ\text{C}$	$\pm(0.05\%$ of rdg + 0.3 $^\circ\text{C}$)	$\pm(0.1\%$ of rdg + 1.5 $^\circ\text{C}$)	0.1 $^\circ\text{C}$
	Ni100 DIN ^{*6}	-60.0 to 180.0 $^\circ\text{C}$			
	Ni120 ^{*7}	-70.0 to 200.0 $^\circ\text{C}$			
	Pt50 ^{*5}	-200.0 to 550.0 $^\circ\text{C}$	$\pm(0.05\%$ of rdg + 0.3 $^\circ\text{C}$)	$\pm(0.1\%$ of rdg + 1.5 $^\circ\text{C}$)	
	Cu10 GE ^{*8}	-200.0 to 300.0 $^\circ\text{C}$			
	Cu10 L&N ^{*8}	-200.0 to 300.0 $^\circ\text{C}$	$\pm(0.05\%$ of rdg + 0.7 $^\circ\text{C}$)	$\pm(0.2\%$ of rdg + 2.5 $^\circ\text{C}$)	
	Cu10 WEED ^{*8}	-200.0 to 300.0 $^\circ\text{C}$			
	Cu10 BAILEY ^{*8}	-200.0 to 300.0 $^\circ\text{C}$	$\pm(0.05\%$ of rdg + 0.3K)	$\pm(0.1\%$ of rdg + 1.5K)	0.1K
J263B	0.0 to 300.0K				
DI	Level	Vth = 2.4 V	Threshold level accuracy: ± 0.1 V		
	Contact input	ON for 1 k Ω or less, OFF for 100 k Ω or more (parallel capacitance: 0.01 μF or less) ^{*9}			

*1 R, S, B, K, E, J, T: ANSI, IEC 584, DIN IEC 584, JIS C 1602-1995

*2 L: Fe-CuNi, DIN43710/U: Cu-CuNi, DIN 43710

*3 N: Nicrosil-Nisil, IEC 584, DIN IEC 584

*4 W: W-5% RE/W-26% Re (Hoskins Mfg Co)

*5 Pt50: JIS C 1604-1981, JIS C 1606-1986/Pt100: JIS C 1604-1989, JIS C 1606-1989, IEC 751, DIN IEC 751/JPt100: JIS C 1604-1981, JIS C 1606-1989

*6 SAMA/DIN

*7 McGRAW EDISON COMPANY

*8 Guaranteed accuracy range Cu10 GE: -84.4 to 170.0 $^\circ\text{C}$ /Cu10 L&N: -75.0 to 150.0 $^\circ\text{C}$ /Cu10 WEED: -20.0 to 250.0 $^\circ\text{C}$ /Cu10 BAILEY: -20.0 to 250.0 $^\circ\text{C}$

*9 Measured using a measurement current of approximately 10 μA at 200-mV range. Threshold level is approximately 0.1 V.

4.5 10-CH, Medium-Speed Universal Input Module Specifications

The inputs indicated below can be used on MXLOGGER or the MX100/DARWIN API (software sold separately).

Input	Measurement Range Type	Rated Measurement Range	Measurement Accuracy		Highest Resolution (1 Digit)
			Integration Time: 16.67 ms or More	Integration Time: 1.67 ms	
DC voltage	60 mV (high res.)	0.000 to 60.000 mV	$\pm(0.05\%$ of rdg + 20 digits)	$\pm(0.1\%$ of rdg + 100 digits)	1 μ V
	1 V	-1.0000 to 1.0000 V	$\pm(0.05\%$ of rdg + 2 digits)	$\pm(0.1\%$ of rdg + 10 digits)	100 μ V
	6 V (high res.)	0.0000 to 6.0000 V	$\pm(0.05\%$ of rdg + 20 digits)	$\pm(0.1\%$ of rdg + 100 digits)	100 μ V
Thermocouple (excludes RJC accuracy, when burnout is OFF)	PLATINEL	0.0 to 1400.0°C	$\pm(0.05\%$ of rdg + 1°C)	$\pm(0.1\%$ of rdg + 4°C)	0.1°C
	PR40-20	0.0 to 1900.0°C	$\pm(0.05\%$ of rdg + 2.5°C) Except 300 to 700°C: $\pm 6^\circ\text{C}$ less than 300°C: not guaranteed	$\pm(0.1\%$ of rdg + 12°C) Except 300 to 700°C: $\pm 25^\circ\text{C}$ less than 300°C: not guaranteed	
	NiNiMo	0.0 to 1310.0°C	$\pm(0.05\%$ of rdg + 0.7°C)	$\pm(0.1\%$ of rdg + 2.7°C)	
	WRe3-25	0.0 to 2400.0°C	$\pm(0.05\%$ of rdg + 2°C) Except 0 to 200°C: $\pm 2.5^\circ\text{C}$ 2000°C or higher: $\pm(0.05\%$ of rdg + 4°C)	$\pm(0.1\%$ of rdg + 7°C) Except 0 to 200°C: $\pm 12^\circ\text{C}$ 2000°C or higher: $\pm(0.1\%$ of rdg + 11°C)	
	W/WRe26	0.0 to 2400.0°C	$\pm(0.05\%$ of rdg + 2°C) Except 100 to 300°C: $\pm 4^\circ\text{C}$ less than 100°C: not guaranteed	$\pm(0.1\%$ of rdg + 8.5°C) Except 100 to 300°C: $\pm 12^\circ\text{C}$ less than 100°C: not guaranteed	
	N (AWG14)	0.0 to 1300.0°C	$\pm(0.05\%$ of rdg + 0.7°C)	$\pm(0.1\%$ of rdg + 3.5°C)	
	XK GOST	-200.0 to 600.0°C	$\pm(0.05\%$ of rdg + 0.5°C) Except -200 to 0°C: $\pm(0.2\%$ of rdg + 0.7°C)	$\pm(0.1\%$ of rdg + 2.5°C) Except -200 to 0°C: $\pm(1\%$ of rdg + 2.5°C)	
RTD (Measurement current: 1 mA)	Cu10 at 20°C alpha = 0.00392	-200.0 to 300.0°C	$\pm(0.1\%$ of rdg + 2°C)	$\pm(0.2\%$ of rdg + 5°C)	0.1°C
	Cu10 at 20°C alpha = 0.00393	-200.0 to 300.0°C			
	Cu25 at 0°C alpha = 0.00425	-200.0 to 300.0°C	$\pm(0.1\%$ of rdg + 0.5°C)	$\pm(0.2\%$ of rdg + 2°C)	
	Cu53 at 0°C alpha = 0.00426035	-50.0 to 150.0°C	$\pm(0.05\%$ of rdg + 0.3°C)	$\pm(0.1\%$ of rdg + 1.5°C)	
	Cu100 at 0°C alpha = 0.00425	-50.0 to 150.0°C			
	Pt25 (JPt100 x 1/4)	-200.0 to 550.0°C	$\pm(0.1\%$ of rdg + 0.5°C)	$\pm(0.2\%$ of rdg + 2°C)	
	Cu10 GE (high res.)	-200.0 to 300.0°C	$\pm(0.1\%$ of rdg + 2°C)	$\pm(0.2\%$ of rdg + 5°C)	
	Cu10 L&N (high res.)	-200.0 to 300.0°C			
	Cu10 WEED (high res.)	-200.0 to 300.0°C			
	Cu10 BAILEY (high res.)	-200.0 to 300.0°C			
	Pt100 GOST	-200.0 to 600.0°C	$\pm(0.05\%$ of rdg + 0.3°C)	$\pm(0.1\%$ of rdg + 1.5°C)	
	Cu100 GOST	-200.0 to 200.0°C			
	Cu50 GOST	-200.0 to 200.0°C			
	Cu10 GOST	-200.0 to 200.0°C			

Measurement interval, integration time, and filter:

Measurement Interval	Integration Time	Burnout Detection Cycle	Filter	Rejected Noise and Notes
100 ms	1.67 ms	1 s ⁻¹	Rectangular	600 Hz and its integer multiples ²
200 ms				60 Hz and its integer multiples
500 ms	16.67 ms	Measurement interval		50 Hz and its integer multiples
	20 ms			Automatically detects the power supply frequency and set 16.67 or 20 ms
1 s	36.67 ms		Trapezoidal	50 Hz or 60 Hz and their integer multiples
2 s	100 ms		Rectangular	10 Hz and its integer multiples
5, 10, 20, 30, 60 s	200 ms		Cos	Fc = 5-Hz low-pass filter

*1 When the measurement interval is 100 ms, burnout is detected in one channel per measurement interval. Therefore, if measurement is started in a burnout condition or after a burnout occurs, burnout cannot be detected for up to 10 measurements (approximately 1 second).

*2 Since the power supply frequency noise is not rejected, the measured values may fluctuate especially with temperature measurement. In such cases, set the measurement interval to 500 ms or higher, or use the 4-CH, High-Speed Universal Input Module.

Reference junction compensation:

Switch between external and internal on each channel, remote RJC function available

Reference junction compensation accuracy:

When measuring temperature greater than or equal to 0°C and when the temperature of the input terminal is balanced

Type R, S, W: $\pm 1^\circ\text{C}$

Type K, J, E, T, N, L, U, XK GOST: $\pm 0.5^\circ\text{C}$

Type N(AWG14), PLATINEL, NiNiMo, WRe3-25, W/WRe26: $\pm 1^\circ\text{C}$

Note: The internal reference junction compensation is fixed to 0°C for type B and PR40-20

4.5 10-CH, Medium-Speed Universal Input Module Specifications

Maximum input voltage:	DC voltage at 1-V range or less, thermocouple, RTD, and DI (contact): ± 10 VDC (continuous) Other measurement ranges: ± 120 VDC (continuous)
Normal-mode voltage:	DC voltage, thermocouple, DI (LEVEL): 1.2 times the range rating or less (50/60 Hz, peak value including the signal component) RTD 100 Ω : 50 mV peak RTD 10 Ω , 25 Ω , 50 Ω : 10 mV peak
Normal-mode rejection ratio:	For integration time of 16.67 ms or more: 40 dB or more (50/60 Hz $\pm 0.1\%$) For integration time of 1.67 ms: 50/60 Hz is not rejected The RTD ranges indicate the voltage conversion value when measurement current applied.
Common-mode voltage:	600 VACrms (50/60 Hz), reinforced (double) insulation
Common-mode rejection ratio:	The RTD ranges indicate the voltage conversion value when measurement current applied. For integration time is 16.67 ms or more: 120 dB or more For integration time is 1.67 ms or more: 80 dB or more (50/60 Hz $\pm 0.1\%$, 500 Ω unbalanced, between the minus terminal and ground)
Common-mode voltage between channels:	120 VACrms (50/60 Hz)
Noise rejection:	Rejection by the integrating A/D converter and the use of low pass filters
Input resistance:	DC voltage at 1 V range or less, thermocouple range: 10 M Ω or more DC voltage at 2 V range or more: Approx. 1 M Ω
Insulation resistance:	20 M Ω or more (500 VDC) between the input and ground
Input bias current:	10 nA or less (except for burnout setting)
Withstand voltage:	1000 VAC (50/60 Hz) for one minute between input terminals 3700 VAC (50/60 Hz) for one minute between the input terminal and earth terminal
Input signal source resistance:	DC voltage and thermocouple: 2 k Ω or less RTD 50 Ω and 100 Ω systems: 10 Ω or less per cable RTD 10 Ω and 25 Ω systems: 1 Ω or less per cable
Thermocouple burnout:	Detection at a specified detection interval per measurement interval and detection within the thermocouple range (detection ON/OFF possible) Up/Down setting is possible 2 k Ω or less: normal, 200 k Ω or more: line broken (Shunt capacity of 0.01 μ F or less), detection current of approximately 10 μ A, and detection time of approximately 2 ms
Shunt capacity during RTD:	0.01 μ F or less
Power consumption:	Approximately 1.2 W
External dimensions:	Approximately 57 (W) \times 131 (H) \times 151 (D) mm (including the terminal cover)
Weight:	Approximately 0.5 kg
Terminal type:	Clamp, terminal board is detachable
Applicable wire size:	0.14 to 1.5 mm ² (AWG26 to 16)

Effects of Operating Conditions

The specifications below apply when the integration time is 16.67 ms or more.

Warm-up time: At least 30 minutes after power-up

Effects of ambient temperature:

The effect received by changes in 10°C increments of the ambient temperature is

$\pm(0.05\%$ of rdg + 0.05% of range) or less

However, $\pm(0.2\%$ of range + 1 digit) for Cu10 Ω

Effects of power fluctuation:

Meets the accuracy specifications for AC power supply in the range 90 to 132 V and 180 to 250 V

Effects of magnetic field:

The fluctuation in external magnetic fields for AC (50/60 Hz) 400 A/m is

$\pm(0.1\%$ of rdg + 10 digits) or less

Effects from the signal source resistance:

Effects on DC voltage and thermocouple from a fluctuation of 1 k Ω in the signal source resistance

DC voltage: 1 V range or less $\pm 10 \mu\text{V}$ or less

2 V range or higher $\pm 0.15\%$ of rdg or less

Thermocouple: $\pm 10 \mu\text{V}$ or less

RTD: Fluctuation due to 10 Ω change per cable (same resistance for the three wires); 100 Ω system: $\pm 0.1^\circ\text{C}$ or less, systems other than 100 Ω : $\pm 1.0^\circ\text{C}$ or less. Fluctuation due to a difference in the resistance between wires of 40 m Ω (maximum difference among three wires) is approximately 0.1°C (for Pt100)

Effect of position: Horizontal with the feet at the bottom is the rule.

Effects of vibration: The fluctuation that results by applying a sinusoidal vibration along all three axis at a frequency between 10 to 60 Hz and an acceleration of 0.2 m/s² is $\pm(0.1\%$ of rdg + 1 digit) or less

External Dimensions

Unit: mm

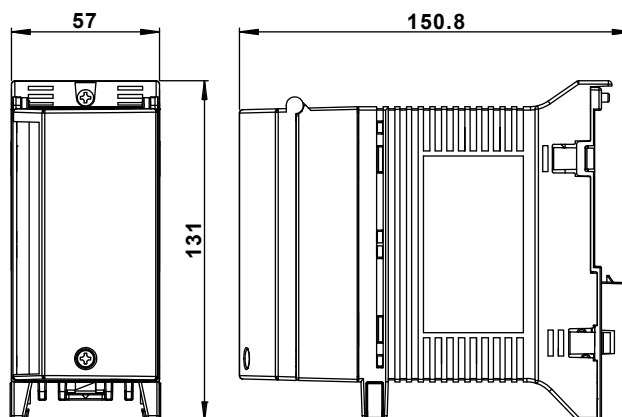

If not specified, the tolerance is $\pm 3\%$. However, in cases of less than 10 mm, the tolerance is ± 0.3 mm.

4.6 30-CH, Medium-Speed DCV/TC/DI Input Module Specifications

Style number:	S3
Type of measurement:	DC voltage, thermocouple, DI (LEVEL, non-voltage contact)
Number of inputs:	30
Module width:	3 modules wide
Input method:	Floating unbalanced input, insulation between channels
A/D resolution:	16 bits ($\pm 20000/\pm 6000/0$ to 60000)
Measurement range and accuracy:	

The accuracy applies to standard operating conditions:
 Ambient temp: 23 $\pm 2^\circ\text{C}$, ambient humidity: 55 $\pm 10\%$ RH, supply voltage: 90 to 250 VAC, power frequency: 50/60 Hz $\pm 1\%$, warm-up time: at least 30 minutes, without adverse conditions such as vibrations.

Input	Measurement Range Type	Rated Measurement Range	Measurement Accuracy		Highest Resolution (1 Digit)	
			Integration Time: 16.67 ms or More	Integration Time: 1.67 ms		
DC voltage	20 mV	-20.000 to 20.000 mV	$\pm(0.05\%$ of rdg + 5 digits)	$\pm(0.1\%$ of rdg + 25 digits)	1 μV	
	60 mV	-60.00 to 60.00 mV	$\pm(0.05\%$ of rdg + 2 digits)	$\pm(0.1\%$ of rdg + 10 digits)	10 μV	
	200 mV	-200.00 to 200.00 mV				
	2 V	-2.0000 to 2.0000 V	$\pm(0.05\%$ of rdg + 5 digits)		100 μV	
	6 V	-6.000 to 6.000 V	$\pm(0.05\%$ of rdg + 2 digits)		1 mV	
	20 V	-20.000 to 20.000 V				
100 V	-100.00 to 100.00 V	10 mV				
Thermocouple (excludes RJC accuracy, when burnout is OFF)	R ^{*1}	0.0 to 1760.0 $^\circ\text{C}$	$\pm(0.05\%$ of rdg + 1 $^\circ\text{C}$) Except 0 to 100 $^\circ\text{C}$: $\pm 3.7^\circ\text{C}$, 100 to 300 $^\circ\text{C}$: $\pm 1.5^\circ\text{C}$ for R and S; 400 to 600 $^\circ\text{C}$: $\pm 2^\circ\text{C}$, less than 400 $^\circ\text{C}$: not guaranteed for B	$\pm(0.1\%$ of rdg + 4 $^\circ\text{C}$) Except 0 to 100 $^\circ\text{C}$: $\pm 10^\circ\text{C}$, 100 to 300 $^\circ\text{C}$: $\pm 5^\circ\text{C}$ for R and S; 400 to 600 $^\circ\text{C}$: $\pm 7^\circ\text{C}$, less than 400 $^\circ\text{C}$: not guaranteed for B	0.1 $^\circ\text{C}$	
	S ^{*1}					
	B ^{*1}					0.0 to 1820.0 $^\circ\text{C}$
	K ^{*1}	-200.0 to 1370.0 $^\circ\text{C}$	$\pm(0.05\%$ of rdg + 0.7 $^\circ\text{C}$) Except -200 $^\circ\text{C}$ to -100 $^\circ\text{C}$: $\pm(0.05\%$ of rdg + 1 $^\circ\text{C}$)			$\pm(0.1\%$ of rdg + 3.5 $^\circ\text{C}$) Except -200 $^\circ\text{C}$ to -100 $^\circ\text{C}$: $\pm(0.1\%$ of rdg + 6 $^\circ\text{C}$)
	E ^{*1}	-200.0 to 800.0 $^\circ\text{C}$	$\pm(0.05\%$ of rdg + 0.5 $^\circ\text{C}$) Except -200 $^\circ\text{C}$ to -100 $^\circ\text{C}$: $\pm(0.05\%$ of rdg + 0.7 $^\circ\text{C}$) for J and L			$\pm(0.1\%$ of rdg + 2.5 $^\circ\text{C}$) Except -200 $^\circ\text{C}$ to -100 $^\circ\text{C}$: $\pm(0.1\%$ of rdg + 5 $^\circ\text{C}$)
	J ^{*1}	-200.0 to 1100.0 $^\circ\text{C}$				
	T ^{*1}	-200.0 to 400.0 $^\circ\text{C}$				
	L ^{*2}	-200.0 to 900.0 $^\circ\text{C}$				
	U	-200.0 to 400.0 $^\circ\text{C}$				
	N ^{*3}	0.0 to 1300.0 $^\circ\text{C}$	$\pm(0.05\%$ of rdg + 0.7 $^\circ\text{C}$)		$\pm(0.1\%$ of rdg + 3.5 $^\circ\text{C}$)	
W ^{*4}	0.0 to 2315.0 $^\circ\text{C}$	$\pm(0.05\%$ of rdg + 1 $^\circ\text{C}$)	$\pm(0.1\%$ of rdg + 7 $^\circ\text{C}$)			
KPvsAu7Fe	0.0 to 300.0K	$\pm(0.05\%$ of rdg + 0.7K)	$\pm(0.1\%$ of rdg + 3.5K)	0.1K		
DI	Level	V _{th} = 2.4 V	Threshold level accuracy: ± 0.1 V			
	Contact input	ON for 1 k Ω or less, OFF for 100 k Ω or more (parallel capacitance: 0.01 μF or less) ^{*5}				

*1 R, S, B, K, E, J, T: ANSI, IEC 584, DIN IEC 584, JIS C 1602-1995

*2 L: Fe-CuNi, DIN43710/U: Cu-CuNi, DIN 43710

*3 N: Nicrosil-Nisil, IEC 584, DIN IEC 584

*4 W: W-5% RE/W-26% Re (Hoskins Mfg Co)

*5 Measured using a measurement current of approximately 10 μA at 200-mV range. Threshold level is approximately 0.1 V.

4.6 30-CH, Medium-Speed DCV/TC/DI Input Module Specifications

The inputs indicated below can be used on MXLOGGER or the MX100/DARWIN API (software sold separately).

Input	Measurement Range Type	Rated Measurement Range	Measurement Accuracy		Highest Resolution (1 Digit)
			Integration Time: 16.67 ms or More	Integration Time: 1.67 ms	
DC voltage	60 mV (high res.)	0.000 to 60.000 mV	$\pm(0.05\%$ of rdg + 20 digits)	$\pm(0.1\%$ of rdg + 100 digits)	1 μ V
	1 V	-1.0000 to 1.0000 V	$\pm(0.05\%$ of rdg + 2 digits)	$\pm(0.1\%$ of rdg + 10 digits)	100 μ V
	6 V (high res.)	0.0000 to 6.0000 V	$\pm(0.05\%$ of rdg + 20 digits)	$\pm(0.1\%$ of rdg + 100 digits)	100 μ V
Thermocouple (excludes RJC accuracy, when burnout is OFF)	PLATINEL	0.0 to 1400.0°C	$\pm(0.05\%$ of rdg + 1°C)	$\pm(0.1\%$ of rdg + 4°C)	0.1°C
	PR40-20	0.0 to 1900.0°C	$\pm(0.05\%$ of rdg + 2.5°C) Except 300 to 700°C: $\pm 6^\circ\text{C}$ less than 300°C: not guaranteed	$\pm(0.1\%$ of rdg + 12°C) Except 300 to 700°C: $\pm 25^\circ\text{C}$ less than 300°C: not guaranteed	
	NiNiMo	0.0 to 1310.0°C	$\pm(0.05\%$ of rdg + 0.7°C)	$\pm(0.1\%$ of rdg + 2.7°C)	
	WRe3-25	0.0 to 2400.0°C	$\pm(0.05\%$ of rdg + 2°C) Except 0 to 200°C: $\pm 2.5^\circ\text{C}$ 2000°C or higher: $\pm(0.05\%$ of rdg + 4°C)	$\pm(0.1\%$ of rdg + 7°C) Except 0 to 200°C: $\pm 12^\circ\text{C}$ 2000°C or higher: $\pm(0.1\%$ of rdg + 11°C)	
	W/WRe26	0.0 to 2400.0°C	$\pm(0.05\%$ of rdg + 2°C) Except 100 to 300°C: $\pm 4^\circ\text{C}$ less than 100°C: not guaranteed	$\pm(0.1\%$ of rdg + 8.5°C) Except 100 to 300°C: $\pm 12^\circ\text{C}$ less than 100°C: not guaranteed	
	N (AWG14)	0.0 to 1300.0°C	$\pm(0.05\%$ of rdg + 0.7°C)	$\pm(0.1\%$ of rdg + 3.5°C)	
	XK GOST	-200.0 to 600.0°C	$\pm(0.05\%$ of rdg + 0.5°C) Except -200 to 0°C: $\pm(0.2\%$ of rdg + 0.7°C)	$\pm(0.1\%$ of rdg + 2.5°C) Except -200 to 0°C: $\pm(1\%$ of rdg + 2.5°C)	

Measurement interval, integration time, and filter:

Measurement Interval	Integration Time	Filter	Rejected Noise and Notes
500 ms	1.67 ms	Rectangular	600 Hz and its integer multiples*
1 s	16.67 ms		60 Hz and its integer multiples
	20 ms		50 Hz and its integer multiples
	Auto		Automatically detects the power supply frequency and set 16.67 or 20 ms
2 s	36.67 ms	Trapezoidal	50 Hz or 60 Hz and their integer multiples
5, 10, 20, 30, 60 s	100 ms	Rectangular	10 Hz and its integer multiples

* Since the power supply frequency noise is not rejected, the measured values may fluctuate especially with temperature measurement. In such cases, set the measurement interval to 1 s or higher, or use the 4-CH, High-Speed Universal Input Module or the 10-CH, Medium-Speed Universal Input Module.

Reference junction compensation:

Switch between external and internal on each channel, remote RJC function available

Reference junction compensation accuracy:

When measuring temperature greater than or equal to 0°C and when the temperature of the input terminal is balanced
Type R, S, W: $\pm 1^\circ\text{C}$

Type K, J, E, T, N, L, U, XK GOST: $\pm 0.5^\circ\text{C}$

Type N(AWG14), PLATINEL, NiNiMo, WRe3-25, W/WRe26: $\pm 1^\circ\text{C}$

Note: The internal reference junction compensation is fixed to 0°C for type B and PR40-20

Maximum input voltage:

DC voltage at 1-V range or less, thermocouple, and DI (contact): ± 10 VDC (continuous)

Other measurement ranges: ± 120 VDC (continuous)

Normal-mode voltage:

DC voltage, thermocouple, DI (LEVEL): 1.2 times the range rating or less (50/60 Hz, peak value including the signal component)

Normal-mode rejection ratio:

For integration time of 16.67 ms or more: 40 dB or more (50/60 Hz $\pm 0.1\%$)

For integration time of 1.67 ms: 50/60 Hz is not rejected

4.6 30-CH, Medium-Speed DCV/TC/DI Input Module Specifications

Common-mode voltage:	600 VACrms (50/60 Hz), reinforced (double) insulation
Common-mode rejection ratio:	For integration time is 16.67 ms or more: 120 dB or more For integration time is 1.67 ms or more: 80 dB or more (50/60 Hz \pm 0.1%, 500 Ω unbalanced, between the minus terminal and ground)
Common-mode voltage between channels:	120 VACrms (50/60 Hz)
Noise rejection:	Rejection by the integrating A/D converter and the use of low pass filters
Input resistance:	DC voltage at 1 V range or less, thermocouple range: 10 M Ω or more DC voltage at 2 V range or more: Approx. 1 M Ω
Insulation resistance:	20 M Ω or more (500 VDC) between the input and ground
Input bias current:	10 nA or less (except for burnout setting)
Withstand voltage:	1000 VAC (50/60 Hz) for one minute between input terminals 3700 VAC (50/60 Hz) for one minute between the input terminal and earth terminal
Input signal source resistance:	DC voltage and thermocouple: 2 k Ω or less
Thermocouple burnout:	Detection at a specified detection interval per measurement interval and detection within the thermocouple range (detection ON/OFF possible) Up/Down setting is possible 2 k Ω or less: normal, 200 k Ω or more: line broken (Shunt capacity of 0.01 μ F or less), detection current of approximately 10 μ A, and detection time of approximately 2 ms
Power consumption:	Approximately 1.2 W
External dimensions:	Approximately 174 (W) \times 131 (H) \times 150 (D) mm (including the terminal cover)
Weight:	Approximately 0.8 kg
Terminal type:	Clamp, or M3 screw terminal (if /H3 option is added)
Applicable wire size:	0.14 to 1.5 mm ² (AWG26 to 16) (for clamp terminals)

Effects of Operating Conditions

The specifications below apply when the integration time is 16.67 ms or more.

Warm-up time: At least 30 minutes after power-up

Effects of ambient temperature:

The effect received by changes in 10°C increments of the ambient temperature is

$\pm(0.05\% \text{ of rdg} + 0.05\% \text{ of range})$ or less

Effects of power fluctuation:

Meets the accuracy specifications for AC power supply in the range 90 to 132 V and 180 to 250 V

Effects of magnetic field:

The fluctuation in external magnetic fields for AC (50/60 Hz) 400 A/m is

$\pm(0.1\% \text{ of rdg} + 10 \text{ digits})$ or less

Effects from the signal source resistance:

Effects on DC voltage and thermocouple from a fluctuation of 1 k Ω in the signal source resistance

DC voltage: 1 V range or less $\pm 10 \mu\text{V}$ or less

2 V range or higher $\pm 0.15\% \text{ of rdg}$ or less

Thermocouple: $\pm 10 \mu\text{V}$ or less

Effect of position: Horizontal with the feet at the bottom is the rule.

Effects of vibration: The fluctuation that results by applying a sinusoidal vibration along all three axis at a frequency between 10 to 60 Hz and an acceleration of 0.2 m/s² is $\pm(0.1\% \text{ of rdg} + 1 \text{ digit})$ or less

External Dimensions

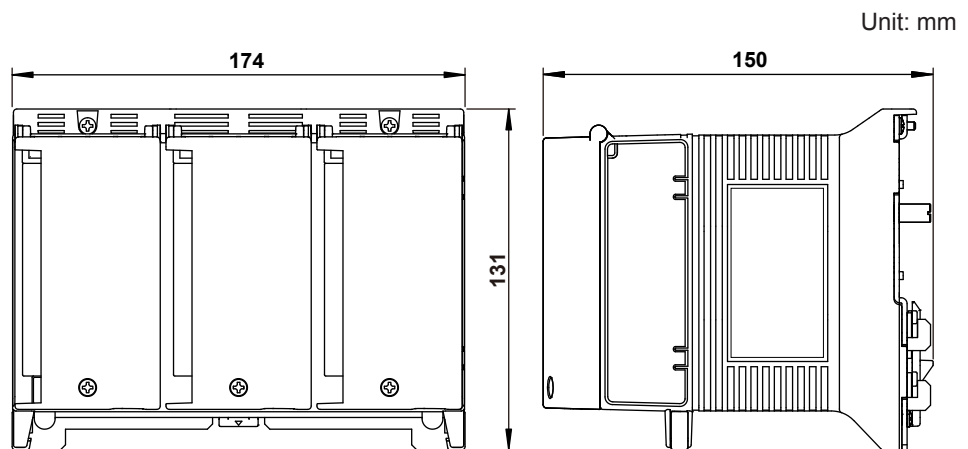

If not specified, the tolerance is $\pm 3\%$. However, in cases of less than 10 mm, the tolerance is $\pm 0.3 \text{ mm}$.

4.7 6-CH, Medium-Speed Four-Wire RTD Resistance Input Module Specifications

Style number:	S2
Type of measurement:	DC voltage, 4-wire RTD, 4-wire resistance, DI (LEVEL, non-voltage contact)
Number of inputs:	6
Input method:	Floating unbalanced input, insulation between channels
A/D resolution:	16 bits ($\pm 20000/\pm 6000/0$ to 60000)
Measurement range and accuracy:	

The accuracy applies to standard operating conditions:
 Ambient temp: $23\pm 2^{\circ}\text{C}$, ambient humidity: $55\pm 10\%$ RH, supply voltage: 90 to 250 VAC, power frequency: 50/60 Hz $\pm 1\%$, warm-up time: at least 30 minutes, without adverse conditions such as vibrations.

Input	Measurement Range Type	Rated Measurement Range	Measurement Accuracy		Highest Resolution (1 Digit)
			Integration Time: 16.67 ms or More	Integration Time: 1.67 ms	
DC voltage	20 mV	-20.000 to 20.000 mV	$\pm(0.05\%$ of rdg + 5 digits)	$\pm(0.1\%$ of rdg + 25 digits)	1 μV
	60 mV	-60.00 to 60.00 mV	$\pm(0.05\%$ of rdg + 2 digits)	$\pm(0.1\%$ of rdg + 10 digits)	10 μV
	200 mV	-200.00 to 200.00 mV			
	2 V	-2.0000 to 2.0000 V	$\pm(0.05\%$ of rdg + 5 digits)		100 μV
	6 V	-6.000 to 6.000 V	$\pm(0.05\%$ of rdg + 2 digits)		1 mV
	20 V	-20.000 to 20.000 V			
	100 V	-100.00 to 100.00 V			10 mV
RTD ⁷ (Measurement current: 1 mA)	Pt100 ¹	-200.0 to 600.0 $^{\circ}\text{C}$	$\pm(0.05\%$ of rdg + 0.3 $^{\circ}\text{C}$)		$\pm(0.1\%$ of rdg + 1.5 $^{\circ}\text{C}$)
	JPt100 ¹	-200.0 to 550.0 $^{\circ}\text{C}$	$\pm(0.05\%$ of rdg + 0.3 $^{\circ}\text{C}$)	$\pm(0.1\%$ of rdg + 1.5 $^{\circ}\text{C}$)	0.01 $^{\circ}\text{C}$
	Pt100 (high res.)	-140.00 to 150.00 $^{\circ}\text{C}$			
	JPt100 (high res.)	-140.00 to 150.00 $^{\circ}\text{C}$	$\pm(0.05\%$ of rdg + 0.3 $^{\circ}\text{C}$)	$\pm(0.1\%$ of rdg + 1.5 $^{\circ}\text{C}$)	0.1 $^{\circ}\text{C}$
	Ni100 SAMA ²	-200.0 to 250.0 $^{\circ}\text{C}$			
	Ni100 DIN ²	-60.0 to 180.0 $^{\circ}\text{C}$			
	Ni120 ³	-70.0 to 200.0 $^{\circ}\text{C}$	$\pm(0.05\%$ of rdg + 0.3 $^{\circ}\text{C}$)	$\pm(0.1\%$ of rdg + 1.5 $^{\circ}\text{C}$)	0.1 $^{\circ}\text{C}$
	Pt50 ⁵	-200.0 to 550.0 $^{\circ}\text{C}$			
	Cu10 GE ⁴	-200.0 to 300.0 $^{\circ}\text{C}$			
	Cu10 L&N ⁴	-200.0 to 300.0 $^{\circ}\text{C}$			
	Cu10 WEED ⁴	-200.0 to 300.0 $^{\circ}\text{C}$	$\pm(0.1\%$ of rdg + 2 $^{\circ}\text{C}$)	$\pm(0.1\%$ of rdg + 1.5 $^{\circ}\text{C}$)	0.1 $^{\circ}\text{C}$
Cu10 BAILEY ⁴	-200.0 to 300.0 $^{\circ}\text{C}$				
J263B	0.0 to 300.0K	$\pm(0.05\%$ of rdg + 0.3K)	$\pm(0.1\%$ of rdg + 1.5K)	0.1K	
DI	Level	V _{th} = 2.4 V	Threshold level accuracy: ± 0.1 V		
	Contact input	ON for 1 k Ω or less, OFF for 100 k Ω or more ⁵			
RTD ⁷ (Measurement current: 0.25 mA)	Pt500 ⁶	-200.0 to 600.0 $^{\circ}\text{C}$	$\pm(0.05\%$ of rdg + 0.3 $^{\circ}\text{C}$)	$\pm(0.1\%$ of rdg + 1.5 $^{\circ}\text{C}$)	0.1 $^{\circ}\text{C}$
	JPt1000 ⁶	-200.0 to 600.0 $^{\circ}\text{C}$			
Resistance ⁷	20 Ω (Measurement current 1 mA)	0.000 to 20.000 Ω	$\pm(0.05\%$ of rdg + 7 digits)	$\pm(0.1\%$ of rdg + 25 digits)	0.001 Ω
	200 Ω (Measurement current 1 mA)	0.00 to 200.00 Ω	$\pm(0.05\%$ of rdg + 3 digits)	$\pm(0.1\%$ of rdg + 15 digits)	0.01 Ω
	2 k Ω (Measurement current 0.25 mA)	0.0 to 2000.0 Ω	$\pm(0.05\%$ of rdg + 3 digits)	$\pm(0.1\%$ of rdg + 10 digits)	0.1 Ω

*1 Pt50: JIS C 1604-1981, JIS C 1606-1986/Pt100: JIS C 1604-1989, JIS C 1606-1989, IEC 751, DIN IEC 751/JPt100: JIS C 1604-1981, JIS C 1606-1989

*2 SAMA/DIN

*3 McGRAW EDISON COMPANY

*4 Guaranteed accuracy range Cu10 GE: -84.4 to 170.0°C /Cu10 L&N: -75.0 to 150.0°C /Cu10 WEED: -20.0 to 250.0°C /Cu10 BAILEY: -20.0 to 250.0°C

*5 Measured using a measurement current of approximately 10 μA at 200-V range. Threshold level is approximately 0.1 V.

*6 The Pt500 resistance table is Pt100 $\times 5$, and the resistance table for Pt1000 is Pt100 $\times 10$.

*7 4-wire RTD, 4-wire resistance

4.7 6-CH, Medium-Speed Four-Wire RTD Resistance Input Module Specifications

The inputs indicated below can be used on MXLOGGER or the MX100/DARWIN API (software sold separately).

Input	Measurement Range Type	Rated Measurement Range	Measurement Accuracy		Highest Resolution (1 Digit)
			Integration Time: 16.67 ms or More	Integration Time: 1.67 ms	
DC voltage	60 mV (high res.)	0.000 to 60.000 mV	$\pm(0.05\%$ of rdg + 20 digits)	$\pm(0.1\%$ of rdg + 100 digits)	1 μ V
	1 V	-1.0000 to 1.0000 V	$\pm(0.05\%$ of rdg + 2 digits)	$\pm(0.1\%$ of rdg + 10 digits)	100 μ V
	6 V (high res.)	0.0000 to 6.0000 V	$\pm(0.05\%$ of rdg + 20 digits)	$\pm(0.1\%$ of rdg + 100 digits)	100 μ V
4-wire RTD (Measurement current: 1 mA)	Cu10 at 20°C alpha = 0.00392	-200.0 to 300.0°C	$\pm(0.1\%$ of rdg + 2°C)	$\pm(0.2\%$ of rdg + 5°C)	0.1°C
	Cu10 at 20°C alpha = 0.00393	-200.0 to 300.0°C			
	Cu25 at 0°C alpha = 0.00425	-200.0 to 300.0°C	$\pm(0.1\%$ of rdg + 0.5°C)	$\pm(0.2\%$ of rdg + 2°C)	
	Cu53 at 0°C alpha = 0.00426035	-50.0 to 150.0°C	$\pm(0.05\%$ of rdg + 0.3°C)	$\pm(0.1\%$ of rdg + 1.5°C)	
	Cu100 at 0°C alpha = 0.00425	-50.0 to 150.0°C			
	Pt25 (JPt100 \times 1/4)	-200.0 to 550.0°C	$\pm(0.1\%$ of rdg + 0.5°C)	$\pm(0.2\%$ of rdg + 2°C)	
	Cu10 GE (high resolution)	-200.0 to 300.0°C	$\pm(0.1\%$ of rdg + 2°C)	$\pm(0.2\%$ of rdg + 5°C)	
	Cu10 L&N (high resolution)	-200.0 to 300.0°C			
	Cu10 WEED (high resolution)	-200.0 to 300.0°C			
	Cu10 BAILEY (high resolution)	-200.0 to 300.0°C			
	Pt100 GOST	-200.0 to 600.0°C	$\pm(0.05\%$ of rdg + 0.3°C)	$\pm(0.1\%$ of rdg + 1.5°C)	
	Cu100 GOST	-200.0 to 200.0°C			
Cu50 GOST	-200.0 to 200.0°C				
Cu10 GOST	-200.0 to 200.0°C	$\pm(0.1\%$ of rdg + 2°C)	$\pm(0.2\%$ of rdg + 5°C)		

Measurement interval, integration time, and filter:

Measurement Interval	Integration Time	Filter	Rejected Noise and Notes
100, 200 ms	1.67 ms	Rectangular	600 Hz and its integer multiples*
500 ms	16.67 ms		60 Hz and its integer multiples
	20 ms		50 Hz and its integer multiples
	Auto		Automatically detects the power supply frequency and set 16.67 or 20 ms
1 s	36.67 ms	Trapezoidal	50 Hz or 60 Hz and their integer multiples
2 s	100 ms	Rectangular	10 Hz and its integer multiples
5, 10, 20, 30, 60 s	200 ms	Cos	Fc = 5-Hz low-pass filter

* Since the power supply frequency noise is not rejected, the measured values may fluctuate especially with temperature measurement and 20 Ω measurement. In such cases, set the measurement interval to 500 ms or higher.

Maximum input voltage:

DC voltage at 1-V range or less, RTD, resistance, and DI (contact):

± 10 VDC (continuous)

Other measurement ranges: ± 120 VDC (continuous)

Normal-mode voltage:

DC voltage, DI (LEVEL): 1.2 times the range rating or less (50/60 Hz, peak value including the signal component). The RTD and resistance ranges indicate the voltage conversion value when measurement current applied.)

Resistance 2 k Ω , RTD 100 Ω , 500 Ω , 1000 Ω systems: 50 mV peak

Resistance 200 Ω , RTD 10 Ω , 25 Ω , 50 Ω systems: 10 mV peak

Resistance 20 Ω : 4 mV peak

Normal-mode rejection ratio:

RTD and resistance ranges are voltage conversion values when the measured current is flowing.

For integration time of 16.67 ms or more: 40 dB or more (50/60 Hz $\pm 0.1\%$)

For integration time of 1.67 ms: 50/60 Hz is not rejected

4.7 6-CH, Medium-Speed Four-Wire RTD Resistance Input Module Specifications

Common-mode voltage:	600 VACrms (50/60 Hz), reinforced (double) insulation
Common-mode rejection ratio:	When integration time is 16.67 ms or more: 120 dB or more When integration time is 1.67 ms or more: 80 dB or more (50/60 Hz \pm 0.1%, 500 Ω unbalanced, between the minus terminal and ground, RTD, and resistance ranges are voltage conversion values when the measured current is flowing.)
Common-mode voltage between channels:	AC voltage, DI: 120 VACrms (50/60 Hz) RTD, resistance: 50 VACrms (50/60 Hz)
Noise rejection:	Rejection by the integrating A/D converter and the use of low pass filters
Input resistance:	DC voltage at 1 V range or less: 10 M Ω or more DC voltage at 2 V range or more: Approx. 1 M Ω
Insulation resistance:	20 M Ω or more (500 VDC) between the input and earth
Input bias current:	10 nA or less
Withstand voltage:	1000 VAC rms (50/60 Hz) for one minute between input terminals (DC voltage and DI) 620 VAC rms (50/60 Hz) for one minute between input terminals (RTD and resistance) 3700 VAC rms (50/60 Hz) for one minute between the input terminal and earth terminal
Input signal source resistance:	DC voltage: 2 k Ω or less Resistance, RTD ranges: 10 Ω or less per wire (common to all ranges)
Shunt capacity:	0.01 μ F or less (when using the RTD or resistance range)
Power consumption:	Approximately 1.2 W
External dimensions:	Approximately 57 (W) \times 131 (H) \times 151 (D) mm (including the terminal cover)
Weight:	Approximately 0.5 kg
Terminal type:	Clamp, terminal board is detachable
Applicable wire size:	0.14 to 1.5 mm ² (AWG26 to 16)

Effects of Operating Conditions

The specifications below apply when the integration time is 16.67 ms or more.

Warm-up time: At least 30 minutes after power-up

Effects of ambient temperature:

The effect received by changes in 10°C increments of the ambient temperature is: $\pm(0.05\%$ of rdg + 0.05% of range) or less

However, $\pm(0.2\%$ of range + 1 digit) for Cu10 Ω

Effects of power fluctuation:

Meets the accuracy specifications for AC power supply in the range 90 to 132 V and 180 to 250 V

Effects of magnetic field:

The fluctuation in external magnetic fields for AC (50/60 Hz) 400 A/m is $\pm(0.1\%$ of rdg + 10 digits) or less

Effects from the signal source resistance:

Effects on DC voltage from a fluctuation of 1 k Ω in the signal source resistance

1 V range or less: $\pm 10 \mu\text{V}$ or less

2 V range or higher: $\pm 0.15\%$ of rdg or less

RTD: Fluctuations resulting from 10 Ω changes per wire:

1000 Ω and 100 Ω systems: $\pm 0.1^\circ\text{C}$ or less

Other than 1000 Ω and 100 Ω systems: $\pm 1.0^\circ\text{C}$ or less

Resistance: Fluctuations resulting from 10 Ω changes per wire: ± 1 digit or less

Effect of position: Horizontal with the feet at the bottom is the rule.

Effects of vibration: The fluctuation that results by applying a sinusoidal vibration along all three axis at a frequency between 10 to 60 Hz and an acceleration of 0.2 m/s² is $\pm(0.1\%$ of rdg + 1 digit) or less

External Dimensions

Unit: mm

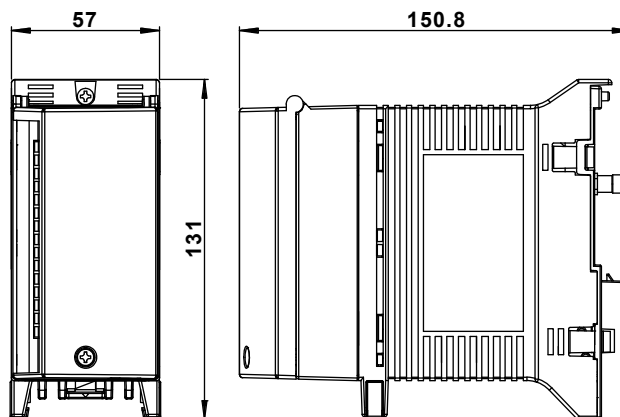

If not specified, the tolerance is $\pm 3\%$. However, in cases of less than 10 mm, the tolerance is ± 0.3 mm.

4.8 4-CH, Medium-Speed Strain Input Module Specifications

Style number: S2
 Number of inputs: 4
 Input type: Strain gauge or strain gauge type sensors (static strain)
 Input method: Floating balanced input, isolated between channels (NDIS is non-isolated)
 Measurement range and accuracy:
 The accuracy applies to standard operating conditions:
 Ambient temp: 23 ±2°C, ambient humidity: 55 ±10% RH, supply voltage: 90 to 250 VAC, power frequency: 50/60 Hz ±1%, warm-up time: at least 30 minutes, without adverse conditions such as vibrations.

One-Gauge Method Conversion Value

Input	Measurement Range Type	Rated Measurement Range	Measurement Accuracy	Resolution	Measurement Accuracy	Resolution
			Integration time: 16.67 ms or more		Integration time: 1.67 ms	
Strain	2000 µStrain	±2000.0 µStrain	±0.5% of range	0.1 µStrain	±2% of range	1 µStrain ^{*1}
	20000 µStrain	±20000 µStrain	±0.3% of range	1 µStrain	±1% of range	2 µStrain ^{*2}
	200000 µStrain	±200000 µStrain	±0.3% of range	10 µStrain	±1% of range	10 µStrain

*1 Display resolution is 0.1 µStrain

*2 Display resolution is 1 µStrain

AD resolution: Equivalent to ±20000 FS display
 However, excludes 1.67 ms integration time

AD integration time:

Measurement Interval	Integration Time	Filter	Rejected Noise and Notes
100 ms	1.67 ms	Rectangular	600 Hz and its integer multiples*
200 ms	16.67 ms		60 Hz and its integer multiples
	20 ms		50 Hz and its integer multiples
	Auto		Automatically detects the power supply frequency and set 16.67 or 20 ms
500 ms	36.67 ms	Trapezoidal	50 Hz or 60 Hz and their integer multiples
1 s	100 ms	Rectangular	10 Hz and its integer multiples
2, 5, 10, 20, 30, 60 s	200 ms	Cos	Fc = 5-Hz low-pass filter

* Since the power supply frequency noise is not rejected, the measured values may fluctuate. In such cases, set the measurement interval to 200 ms or higher.

Gauge connection method:

1-gauge (2 or 3 wire systems), opposing 2-gauge, adjacent 2- or 4-gauge

With clamp terminals, set on a channel basis with switches

Applicable gauge resistance:

100-1000 Ω

Built in resistance of 120 Ω for -B12, and 350 Ω for -B35.

Bridge voltage: Fixed at 2 VDC, accuracy ±5%, compensated with internal Cal

Applicable gauge factor: Fixed at 2.0. Gauge factor can be compensated with the scaling function.

Balance adjustment: Automatic, digital calculation methods

Balance adjustment range:

±10000 µstrain (1-gauge method conversion)

Balance adjustment accuracy:

The measurement accuracy or less:

Resistance accuracy for bridge: ±0.01% ±5ppm/°C

Input resistance: 1 MΩ or more

Allowable wiring resistance: 100 Ω or less

Effect of wiring resistance: NDIS 50 ppm of rdg/Ω (when using remote sensing wire).

Does not compensate for clamp wiring resistance. Depends on the gauge resistance.

4.8 4-CH, Medium-Speed Strain Input Module Specifications

Allowable input voltage:	±10 VDC (between H-L) continuous
Allowable common-mode voltage:	Channel-to-channel: 30 VAC rms Between input and earth: 250 VAC rms (-B12,-B35) 30 VACrms(-NDI) However, NDIS connector shell is connected to earth potential
CMRR*:	For integration time of 16.67 ms or more: 120 dB or more For integration time of 1.67 ms or more: 80 dB or more (voltage conversion value at 50/60 Hz ±0.1%, bridge voltage of 2 V)
NMRR:	For integration time of 16.67 ms or more: 40 dB or more (50/60 Hz ±0.1%) For integration time of 1.67 ms: 50/60 Hz is not rejected. (voltage conversion value with bridge voltage of 2 V)
Insulation resistance*:	Between input and earth: 20 MΩ or more at 500 VDC
Withstand voltage*:	Between input and earth: 2300 VAC for one minute Channel-to-channel: 30 VACrms or less
Power consumption:	Approximately 3 W (one module)
Weight:	Approximately 0.5 kg
External dimensions:	Approx. 57 (W) × 131 (H) × 151 (D) mm (including the terminal cover)
Terminal type:	-B12, -B35: Clamp, terminal board is detachable -NDI: NDIS
Applicable wire size:	0.14 to 1.5 mm ² (AWG26 to 16)(excluding -NDI) * Not applicable in the case of the NDIS terminal.

Effects of Operating Conditions

The specifications below apply when the integration time is 16.67 ms or more.

Warm-up time: At least 30 minutes after power-up

Effects of ambient temperature:

The effect received by changes in 10°C increments of the ambient temperature is:
±(0.1% of range) or less

Effects of power fluctuation:

Meets the accuracy specifications for AC power supply in the range 90 to 132 V and 180 to 250 V

Effects of magnetic field:

The fluctuation in external magnetic fields for AC (50/60 Hz) 400 A/m is ±2% or range or less

Effect of position: Horizontal with the feet at the bottom is the rule.

External Dimensions

Unit: mm

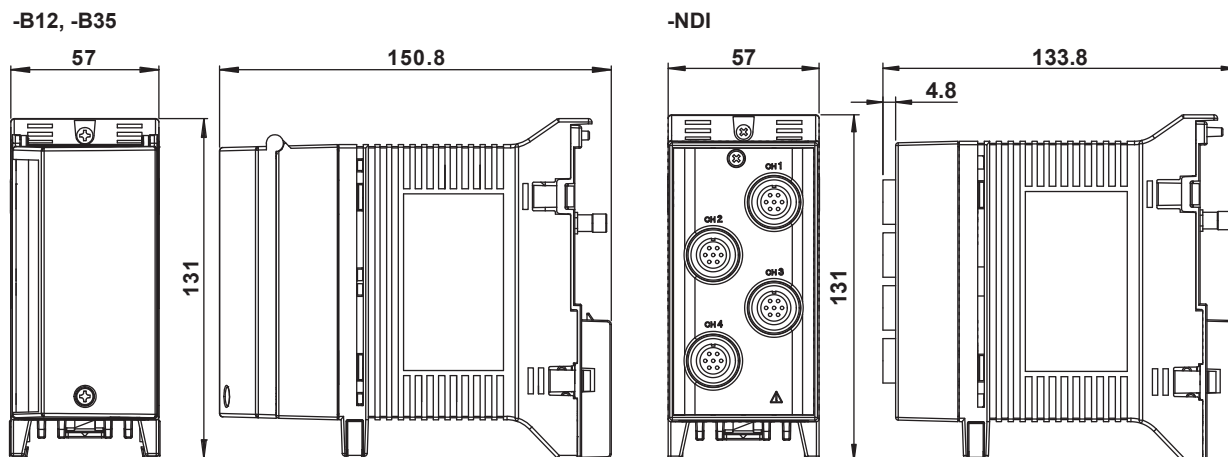

If not specified, the tolerance is ±3%. However, in cases of less than 10 mm, the tolerance is ±0.3 mm.

4.9 10-CH, High-Speed Digital Input Module Specifications

Style number:	S1(-D05), S2(-D24)
Input type:	-D05: contact (non-voltage contact, open collector), and LEVEL (5-V logic) -D24: LEVEL (24 V logic)
Number of inputs:	10
Input format:	-D05: Pull-up at approximately 5 V/approximately 5 k Ω , no insulation between channels -D24: No isolation between channels:
Measurement interval:	Select 10 ms, 50 ms, 100 ms, 200 ms, 500 ms, 1 s, 2 s, 5 s, 10 s, 20 s, 30 s, or 60 s
Filter:	Measurement interval of 5 s or less: Uses the widest ON/OFF width during the detection period (approximately 75% to 90% of the measurement interval). Measurement interval of 5 s or more: Uses the widest ON/OFF width during approximately 4.5 s
Minimum detection pulse width:	Twice the sampling interval or more
Input threshold level:	-D05: Contact (non-voltage contact, open collector): ON at 100 Ω or less and OFF at 100 k Ω or more LEVEL (5-V logic): OFF at 1 V or less and ON at 3 V or more -D24: LEVEL (24 V logic): OFF at 6 V or less and ON at 16 V or more
Hysteresis width:	-D05: Approximately 0.1 V -D24: Approximately 1.5 V
Contact/transistor rating:	Contact with a rating of 15 VDC or greater and 30 mA or greater Vce and Ic are transistors with ratings of 15 VDC or more, and 30 mA or more, respectively.
Maximum input voltage:	-D05: ± 10 V -D24: Approx. ± 50 V
Insulation resistance:	20 M Ω or more (500 VDC) between the input and ground
Withstand voltage:	2300 VAC (50/60 Hz) for one minute between input and earth
Maximum common-mode voltage:	250 VAC rms (50/60 Hz)
Terminal type:	Clamp
Power consumption:	Approximately 1.5 W
Applicable wire size:	0.14 to 1.5 mm ² (AWG26 to 16)
External dimensions:	Approx. 57 (W) \times 131 (H) \times 151 (D) mm (including the terminal cover)
Weight:	Approximately 0.5 kg

External Dimensions

Unit: mm

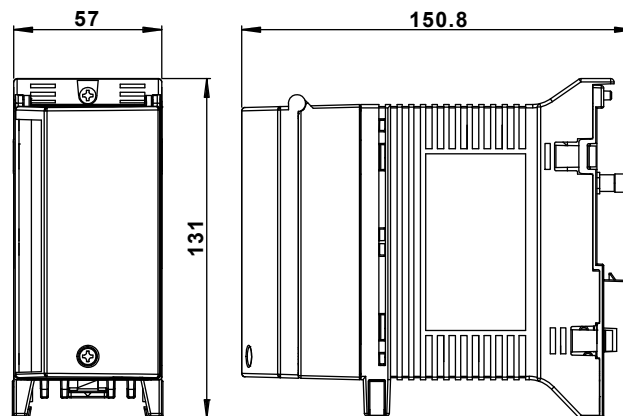

If not specified, the tolerance is $\pm 3\%$. However, in cases of less than 10 mm, the tolerance is ± 0.3 mm.

4.10 8-CH, Medium-Speed Analog Output Module Specifications

Style number:	S2
Number of outputs:	8
Update interval:	Output per 100 ms (not synchronized to the measurement interval)
Output types:	DC voltage, DC current (external 24-V power supply required when using current output)
Rated output range:	Voltage: -10 to 10 V Current: 0 to 20 mA sourcing (for 1-5 V output, 4-20 mA is output)
Max. output range:	Voltage: -11 to 11 V, Current: 0 to 22 mA
Load impedance:	Voltage 5 k Ω or more, Current 600 Ω or less
Accuracy:	$\pm 0.2\%$ of F.S. at the rated output range or less (F.S. = 10 V or 20 mA). However, for current output, accuracy is met at 1 mA or more. The accuracy applies to standard operating conditions: ambient temp: 23 $\pm 2^{\circ}\text{C}$, ambient humidity: 55 $\pm 10\%$ RH, supply voltage: 90 to 250 VAC, power frequency: 50/60 Hz $\pm 1\%$, warm-up time: at least 30 minutes, without adverse conditions such as vibrations.
Output resolution:	12 bits of F.S. or more Setting resolution is as follows (the actual module resolution is rounded). PC Software: -10.000 V to 10.000 V (1 mV resolution) 0.000 mA to 20.000 mA (1 mA resolution) API, MX main unit: Set-10 V to 10 V with -20000 to 20000 digits (or approx. 2000 - 10000 digits for 4-20 mA)
Effects of ambient temperature:	$\pm(50 \text{ ppm of setting} + 50 \text{ ppm of F.S.})$ per degree C or less (F.S. = 10 V or 20 mA)
External power supply:	24 V $\pm 10\%$ (required when using current output) Connect a device with ampacity of 250 mA or more.
Insulation resistance:	20 M Ω or more (500 VDC) between output terminal and earth Across output terminals: non-isolated (- terminal common potential)
Withstand voltage:	2300 VAC (50/60 Hz) for one minute between the output terminal and earth Across output terminals: non-isolated (- terminal common potential)
Power consumption:	Approx. 2.5 W (not including power consumption of external power supply)
Terminal type:	Clamp, attached and removed in units of 4 channels
Applicable wire size:	0.08 to 2.5 mm ² (AWG28 to 12)
External dimensions:	Approx. 57 (W) \times 131 (H) \times 151 (D) mm (including the terminal cover)
Weight:	Approximately 0.5 kg

External Dimensions

Unit: mm

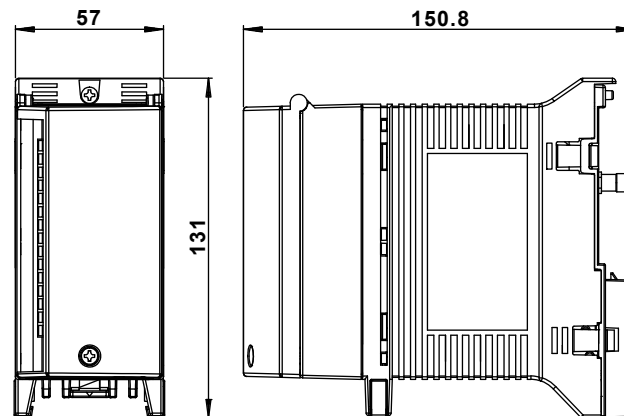

If not specified, the tolerance is $\pm 3\%$. However, in cases of less than 10 mm, the tolerance is ± 0.3 mm.

Setting Value of Span and Preset, and Specified Value of User Output

Analog output setting value span and preset value		Specified Value of User Output (count)
Voltage	Current	
-11.000 V	0.000 mA	-22000
-10.000 V	0.000 mA	-20000
0.000 V	0.000 mA	0
1.000 V	4.000 mA	2000
5.000 V	20.000 mA	10000
5.500 V	22.000 mA	11000
10.000 V	25.000 mA*	20000
11.000 V	25.000 mA*	22000

* Value in calculation. Actually, the value is clipped at approximately 22 mA.

Output Span Setting

Span setting data when setting transmission output

- V mode**

Output voltage [V]	-10.000	10.000
PC data*	-10000	10000

* PC data refers to internal data between the PC and MX100 main unit, and on the PC software, the output value is expressed in the same manner with 3 digits after the decimal point.

- mA mode**

Output voltage [mA]	0.000	20.000
PC data*	0	20000

* PC data refers to internal data between the PC and MX100 main unit, and on the PC software, the output value is expressed in the same manner with 3 digits after the decimal point.

- Limit value of V mode and mA mode**

Mode	Output lower limit ^{*1}	Setting span lower limit	Setting span upper limit	Output upper limit ^{*2}
V mode	-11 [V]	-10 [V]	+10 [V]	+11 [V]
mA mode	0 [mA]	0 [mA]	20 [mA]	22 [mA]

*1 -OVER, preset value

*2 +OVER, preset value

Handling Abnormal Data

Types of Abnormal Data	Output Values
Output data upon startup	Preset value or previously held value can be selected
Data upon error occurrence	Preset value or previously held value can be selected
+OVER	5% of output Full Span
-OVER	-5% of output Full Span

±OVER determination

For user output, ±OVER determination is performed on the PC, and if the limit value is exceeded, it is clipped at that limit value. For transmission output within the same unit, OVER is determined by the MX100 main unit.

±OVER conditions

- When the input channel is ±OVER in the case of transmission output
- When outside the range of ±5% of output Full Span
- When outside the range of voltage -11 V to +11 V, or current 0 mA to 22 mA (accuracy assured at 1 mA or more)

4.11 8-CH, Medium-Speed PWM Output Module Specifications

Style number:	S2
Number of outputs:	8
Update interval:	100 ms minimum (not synchronized to the measurement interval)
Output interval:	1 ms to 300 s (can be set channel by channel)
	However, 1 ms intvl settg rng: 1 ms-30.000 s can be set in units of 1 ms 10 ms intvl settg rng: 10 ms-30.000 s can be set in units of 10 ms
Output types:	Pulse width
Update timing:	After receiving change command, duty is changed from falling edge of the next interval
Pulse interval accuracy:	±100 ppm of setting
External power supply:	4 to 28V
Insulation resistance:	20 MΩ or more (500 VDC) between output terminal and earth Across output terminals: non-isolated
Withstand voltage:	2300 VAC (50/60 Hz) for one minute between the output terminal and earth Across output terminals: non-isolated
Duty resolution:	1 ms interval setting range: 12000 10 ms interval setting range: 60000 However, the PC software sets 0 to 100.000% (0.001% resolution) MX main unit/API, sets 0-100% with 0 to 00000 count.
Duty accuracy (load resistance at 100Ω or less):	1 ms freq. setting rng: the longer of ±0.017% or ±2 μs 10 ms freq. setting rng: the longer of ±0.0035% or ±2 μs If the load impedance is greater than 100 Ω, the output duty may vary.
Output format:	External power supply sourcing
ON resistance:	2 Ω or less (however, when output current is 200 mA or more.)
Output capacity:	1A/ch max, however, 4 A or less total for all modules ^{*1, *2}
	^{*1} A 1A current limit circuit is built in to the output circuit. Once the current limit circuit is ON, the circuit continues to operate unless the external power supply is turned OFF (maintains the output off status). Once the external power supply has been turned OFF, restart the external power supply after checking the load status.
	^{*2} This module has a built-in fuse. The built-in fuse protects against fires or abnormal emissions of heat due to load short-circuiting or other abnormalities.
Power consumption:	Approx. 2.5 W (not including power consumption of external power supply)
Terminal type:	Clamp, attached and removed in units of 4 channels
Applicable wire size:	0.08 to 2.5 mm ² (AWG28 to 12)
External dimensions:	Approx. 57 (W) × 131 (H) × 151 (D) mm (including the terminal cover)
Weight:	Approximately 0.5 kg

External Dimensions

Unit: mm

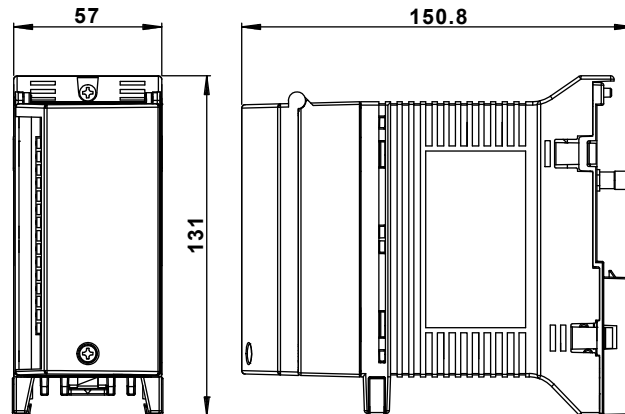

If not specified, the tolerance is $\pm 3\%$. However, in cases of less than 10 mm, the tolerance is ± 0.3 mm.

Setting Value of Span and Preset, and Specified Value of User Output

PWM output setting value span and preset value	Specified Value of User Output (count)
0.000%	0
20.000%	20000
40.000%	40000
60.000%	60000
80.000%	80000
100.000%	100000

Output Span Setting

Span setting data when setting transmission output

Target output [%]	0.000	50.000	100.000
PC data*	0	50000	100000

* PC data refers to internal data between the PC and the MX100 main unit.

Handling Abnormal Data

Types of Abnormal Data	Output Values
Abnormal data upon startup	Preset value or previously held value can be selected
Data upon error occurrence	Preset value or previously held value can be selected
When input channels differ	Preset value or previously held value can be selected
+OVER	Duty 100.000% output
-OVER	Duty 0% output

\pm OVER determination

For command output, \pm OVER determination is performed on the PC, and if the limit value is exceeded, it is clipped at that limit value. For retransmission output, OVER is determined by the MX100 main unit.

\pm OVER conditions

- When duty exceeds 0.000-100.000%
- When the input channel is \pm OVER in the case of transmission output

Setting by Pulse Interval Range

When the pulse interval is 10 ms

Pulse interval	PC setting value
10 ms	1
20 ms	2
300.00 s	30000

When the pulse interval is 1 ms

Pulse interval	PC setting value
1ms	1
2ms	2
30.000 s	30000

4.12 Operations Common to the 8-CH Medium-Speed Analog Output Module and the 8-CH Medium Speed PWM Output Module

Specifications Regarding Settings (by Module)

Set Channels (Module)	Setting Contents	Setting	Note	
Output channels (AO, PWM)	Span setting range	AO (V) -10.000 to 10.000 V	-	-
		AO (mA) 0.000 to 20.000 mA	-	-
		PWM 0.000 to 100.000%	-	-
	Preset value setting range	AO (V) -11.000 to 11.000 V	-	-
		AO (mA) 0.000 to 22.000 mA	-	-
		PWM 0.000 to 100.000%	-	-
	Setting span (minimum, maximum) specified in reverse	Y	-	
	Setting span (minimum, maximum) specified as the same	No	-	
Computation Channels	Reading of in equations	Transmission output channels within units	No	-
		Transmission output channels between units	No	-
		Manual output channel	Y	Depending on function
		Pattern output channel	Y	dedicated

Specifications Regarding Settings Changes (Automatic Setting upon Change Event)

When a setting change occurs, transmission output on all channels specified for transmission output within units is set from disabled to enabled. This operation is performed even if the channel whose setting was changed is not a transmission output channel.

Overview of Output Operation When Setting Holding of Previous Value of Transmission Output

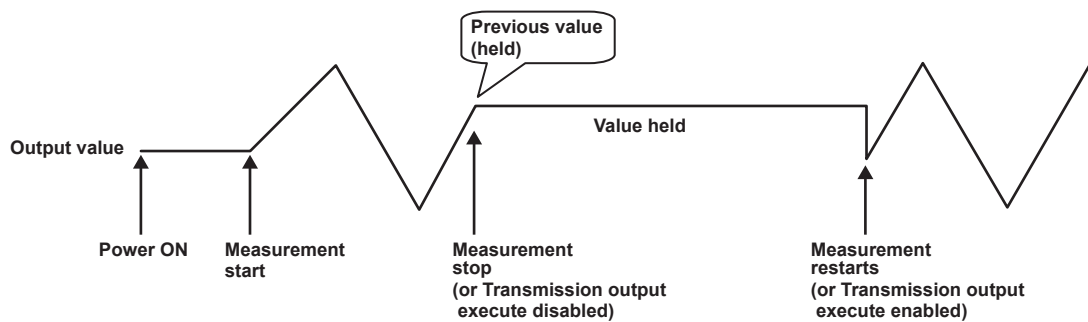

4.13 10-CH, Medium-Speed Digital Output Module Specifications

Style number:	S1
Number of outputs:	10
Contact mode:	A contact (SPST)
Update interval:	Output per 100 ms (not synchronized to the measurement interval)
Contact capacity:	250 VDC/0.1 A, 250 VAC/2 A, or 30 VDC/2A (resistance load)
Contact life*:	100,000 times at rated load (typical) 20,000,000 times at no load (typical)
	* The contact life varies depending on the load conditions and the environment in which it is used.
Insulation resistance:	20 MΩ or more (500 VDC) between output terminal and earth 20 MΩ or more (500 VDC) between the output terminals
Withstand voltage:	2300 VAC (50/60 Hz) for one minute between the output terminal and earth 2300 VAC (50/60 Hz) for one minute between output terminals
Maximum common-mode voltage:	250 VACrms (50/60 Hz)
Power consumption:	Approximately 2 W (when all relays are turned ON)
Terminal type:	Clamp, attached and removed in units of 5 channels
Applicable wire size:	0.08 to 2.5 mm ² (AWG28 to 12)
External dimensions:	Approx. 57 (W) × 131 (H) × 151 (D) mm (including the terminal cover)
Weight:	Approximately 0.5 kg

External Dimensions

Unit: mm

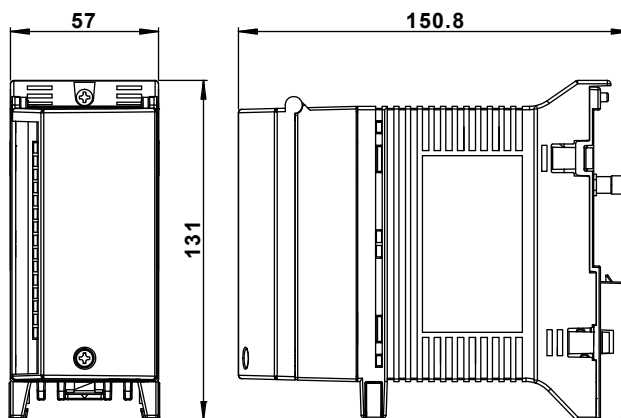

If not specified, the tolerance is $\pm 3\%$. However, in cases of less than 10 mm, the tolerance is ± 0.3 mm.

5.1 Overview of Functions

The following functions are added when the /DS option functions are enabled. For the interval (guideline) of saving of data to the CF card, see “Saving Data to the CF Card” in section 1.2.

- Operation mode retention function
- Saving data to the CF card (Dual Save function)
- Measurement and recording start/stop function (data acquisition using only the MX100)

Operation Mode Retention Function

When the power is turned ON, the operation mode last active before the power was cut is automatically restored.

When automatic recovery is performed, after the self-check completes, [- -] is displayed on the 7-segment LED for 0.3 seconds.

Saving data to the CF Card

Transmission of measured data to the PC via communications and saving of measured data to the CF card in the main module can be carried out simultaneously.

The standard function saves data to the CF card only if communication with the PC is disconnected during recording by the PC software. With the **Dual Save function**, measured data is saved to the CF card during recording by the PC software.

Starting and Stopping Measurement and Recording

In situations where the MX100 cannot be connected to a PC, this function can be used to acquire data on the MX100 by itself. You can start and stop measurement and saving of data to the CF card by holding down the CF card control switch (access stop switch) for five seconds (hereinafter referred to as **5s-SW**).

Start time: Starts saving to the CF card one second after measurement starts.

Stop time: Saves data to the CF card up to the moment measurement stops.

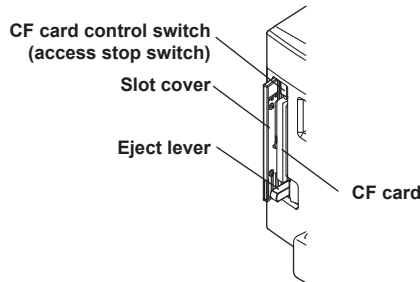

Enabling the Functions

Change the dip switches as shown in the figure. When all dip switches are ON (factory default), the /DS option functions do not operate.

Turn OFF the power to the MX100 before changing dip switch settings.

When the power is restored, the instrument starts up with the /DS option functions enabled.

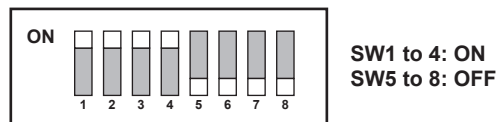

5.2 Explanation of Functions

The PC software programs referred to in this section are the MX100 Standard Software and MXLOGGER (sold separately). In the explanatory figures provided, **Idle**, **Measure**, and **Backup** refer to idling mode, measurement mode, and backup mode respectively, and **AlarmDO** refers to alarm output (see "Alarms" in section 1.2).

Operation Mode Retention Function

When the power is turned ON, the operation mode last active before the power was cut is automatically restored. During backup mode, the instrument returns to measurement mode, and then transitions to backup mode after 1 second.

Idle (idling mode):

A wait mode in which no measurement takes place. Alarms are also not detected.

Measure (measurement mode):

Measurement and alarm detection are performed, and data is not saved to the CF card.

Backup (backup mode):

Measurement, alarm detection, and saving of data to the CF card are performed.

7-Segment LED Display

When the power is turned ON, after the self check operation display, the following is displayed.
Function Confirmation Indication

--

Operation Mode Retention

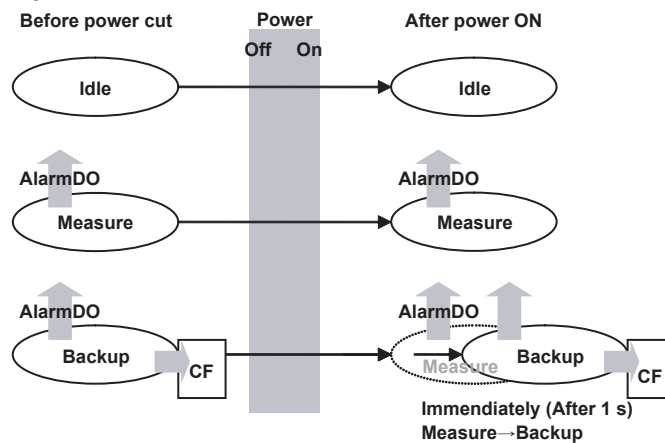

Operation Mode Transitions

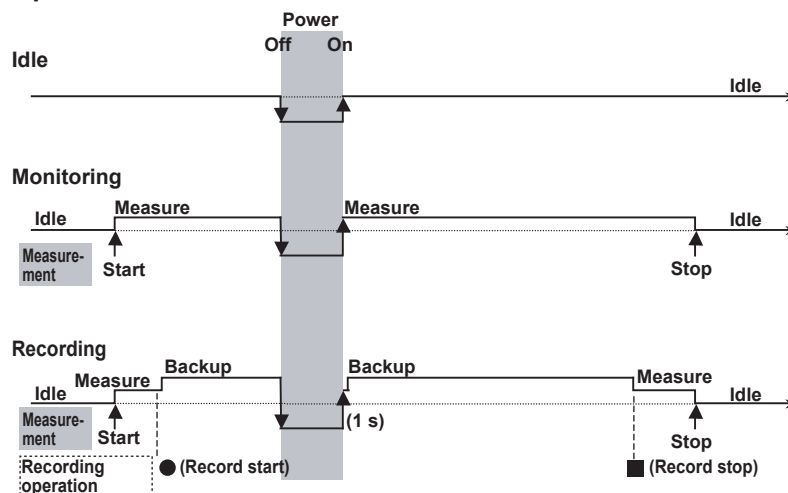

Saving data to the CF Card

Transmission of measured data to the PC via communications and saving of measured data to the CF card in the main module can be carried out simultaneously. The standard function saves data to the CF card only if communication with the PC is disconnected during recording by the PC software. With the **Dual Save function**, measured data is saved to the CF card during recording by the PC software. This function is also available when programming applications with the MX100/DARWIN API (use in combination with the "Backup" recording command and the "GetData" data acquisition command).

Note

Under normal functionality, saving of data to the CF card is for backup when communications are disconnected. The following shows the operation.

Backup When Communication Is Cut

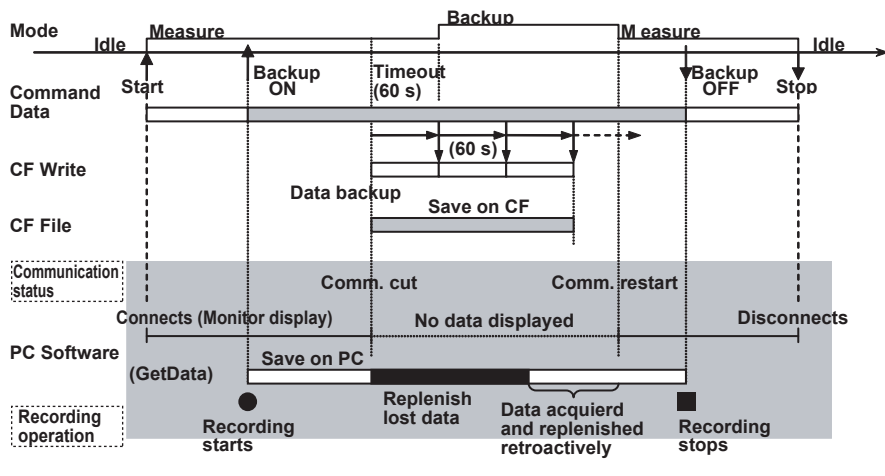

Dual Save Function (When Using the PC Software)

• Normal Operation

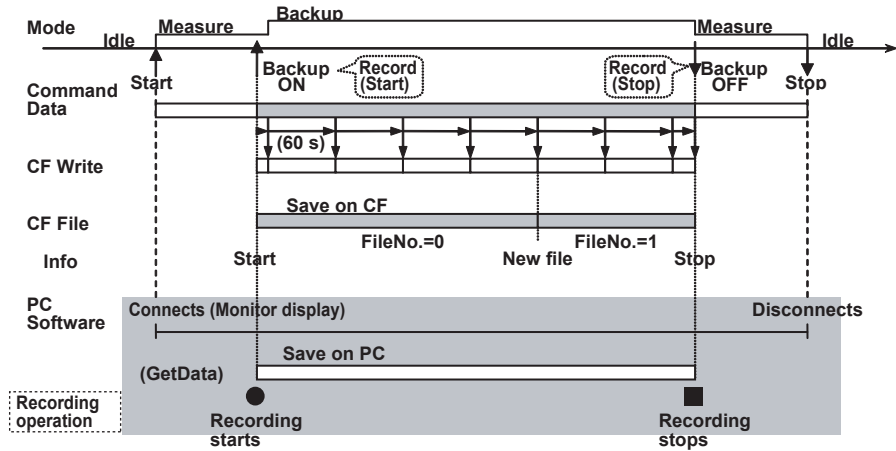

• Operation Mode Retention/Auto Restore

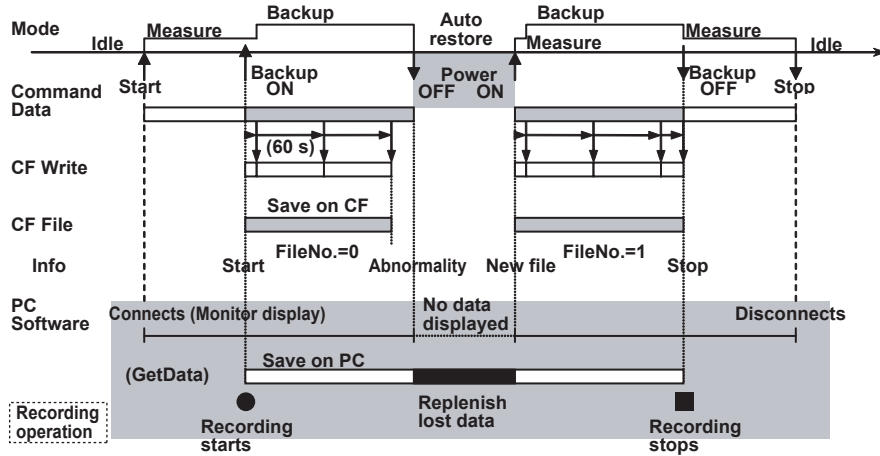

Note

When using the MX100 Standard Software, the data saved to the PC and CF card depends on the following.

Setting	Screen and Items	Data saved to PC	Data saved to the CF Card
Save interval	[Log. conditions] screen	[Recording interval]	[Monitoring interval]*
Saved channels	[Channel] screen	[Record]	[Monitor]

* Measurement groups of the save monitoring interval are saved to the same file.

When the Recording interval and Monitoring interval, and the Record and Monitor settings are set the same, measured data is saved to the PC and the CF card under the same conditions.

Dual Save Function (When Using an Application Based on the MX100/DARWIN API)

• **Application Example 1**

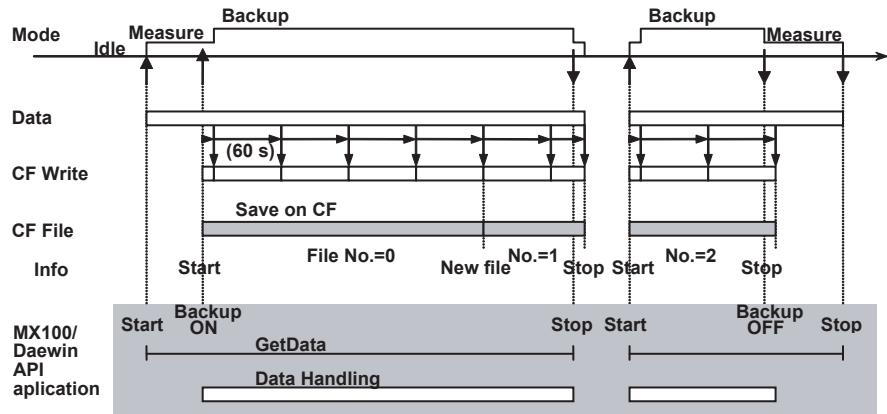

Data handling on the PC after Using GetData (Display, Computation, Thinning, Saving, Etc.)

• **Application Example 2**

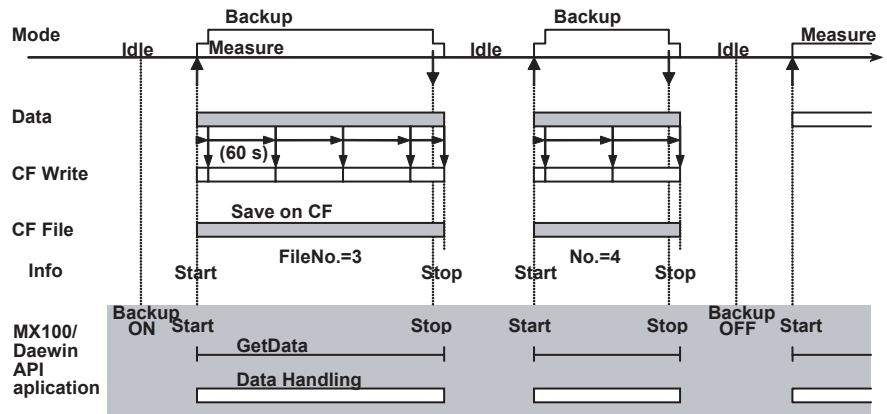

You can set recording status settings before and after measurement starts or stops (Backup ON/OFF). Saving of data to the CF card can be linked with the Start/Stop function.

Note

The file number of a data file saved to the CF card using an MX100/DARWIN API application is the consecutive number assigned during use of the API application.

Output Operation of the Dual Save Function

If the Dual Save function is used, output from digital, analog, and PWM output modules may experience delay when data is being saved to the CF card.

When stopping recording in particular, a delay of several seconds may occur due to the save stop operation.

Starting and Stopping Measurement and Recording

In situations where the MX100 cannot be connected to a PC, this function can be used to acquire data on the MX100 by itself.

You can start and stop measurement and saving of data to the CF card by holding down the CF card control switch for five seconds (the **5s-SW function**).

Changing Modes with 5s-SW

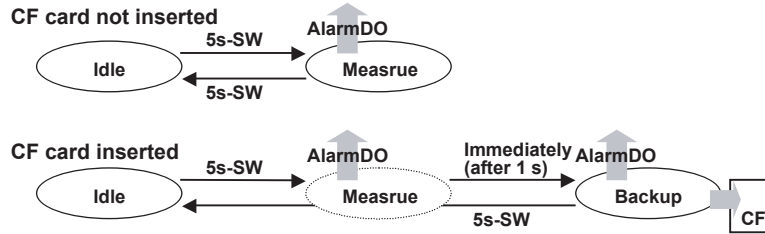

If measurement fails to start, [E_r] appears on the 7-segment LED for one second.

CAUTION

Do not use the 5 s-SW function when the MX100 and PC software are connected. The PC software will experience an error.

Note

- You can connect to the PC software after starting saving of data to the CF card using the 5 s-SW function.
- The CF card can only be removed or inserted while in idle mode.

Operation When the CF Card Is Not Inserted

• Normal Operation

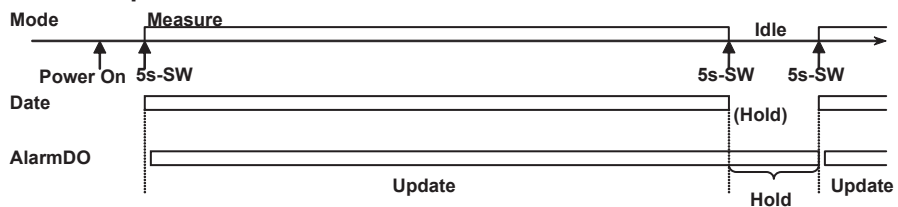

• Operation When Power Cut and PC Software Connected

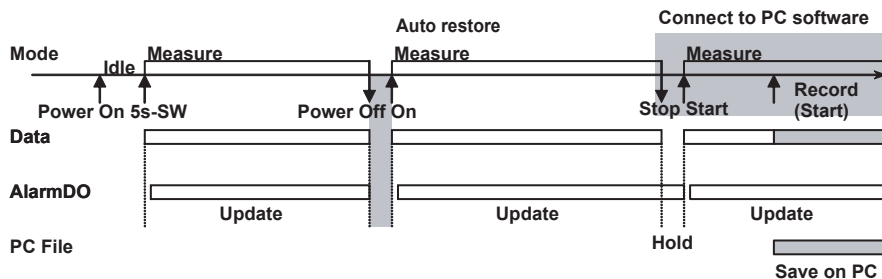

Operation When the CF Card Is Inserted

CF Write (Data Write Timing):

The timing at which data is written to a file (CF File) on the CF card. Starting with the second write operation (append), the operation is timed according to the save interval. The write count is the count at which the file reaches 5 MB when measuring at the shortest measurement interval. When the count is reached the file closes, and a new file is created upon the next write operation. You can choose a file creation mode of Rotary or FullStop mode (see "Data Storage" in section 4.2).

Info (File Information):

Files have numbers and start/stop conditions. You can access this information using the PC software's Viewer function.

• **Normal Operation**

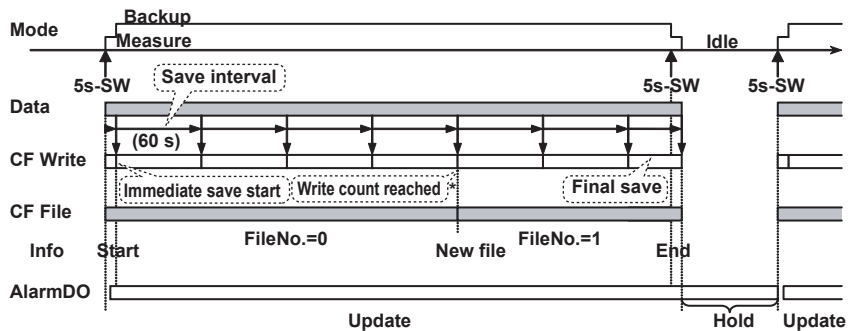

* Write count in this figure is an example only.
Count at which the file reaches 5 MB at the shortest measurement interval.

Alarm Output (AlarmDO) is the same as when the CF card is not inserted.

• **When a Power Cut**

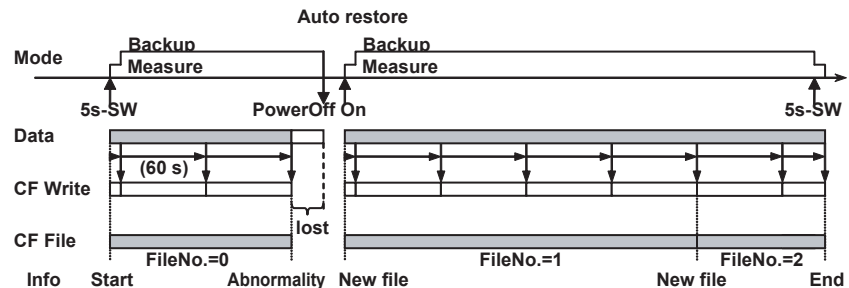

• **When Operating the Access Stop Switch (CF-SW)**

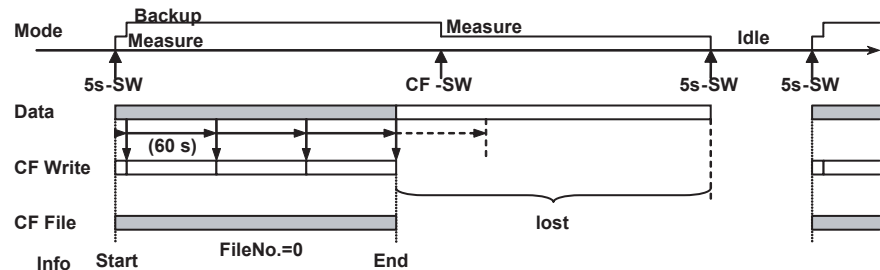

5.2 Explanation of Functions

- If a Media Error Occurs When Saving Data to the CF Card

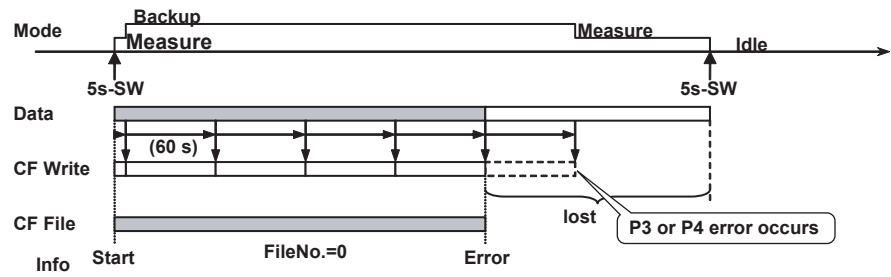

- When Connecting to the PC Software

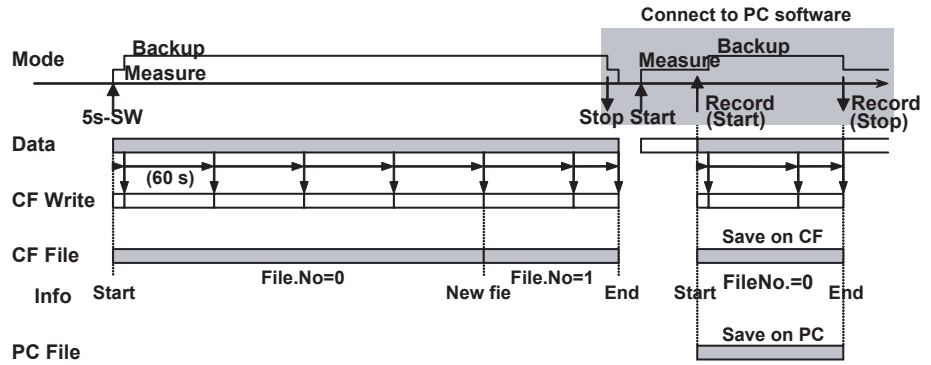

5.3 CF Card Data File

File Name

Data files created on the CF card using the 5s-SW or Dual Save function are named based on the date and time of creation (month and date), as follows.

MDDIXXXX.MXD

M: Month (local time) when file created, 1 to 9, X (October), Y (November), Z (December)

DD: Date when file created (local time), 1 to 31

I: Meas. interval number 0 to 2

XXXX: Sequence number (incremented by 1 each time new file created) 0000-9999

MXD: Extension (uppercase characters) specific to the MX100

Under normal functioning, the date (month and date) of backup start is used (see "File name" under "Data Storage" in section 4.2).

File Name

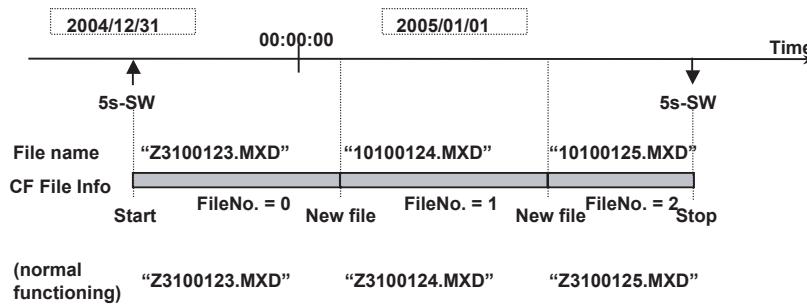

Index

Symbols

/DS option 5-1

Numeric

10-CH, High-Speed Digital Input Module 1-26
 10-CH, Medium-Speed Digital Output Module 1-35
 10-CH, Medium-Speed Universal Input Module 1-16
 10-CH, Pulse Input Module 1-5
 24V logic input 2-16
 30-CH, Medium-Speed DCV/TC/DI Input Module 1-18
 4-CH, High-Speed Universal Input Module 1-14
 4-CH, Medium-Speed Strain Input Module 1-22
 5s-SW 5-6
 5V logic input 2-16
 6-CH, Medium-Speed Four-Wire RTD Resistance Input... 1-20
 7-segment LED 1-10, 3-1
 8-CH, Medium-Speed Analog Output Module 1-27
 8-CH, Medium-Speed PWM Output Module 1-28
 8-CH Medium-Speed A/O Module and the PWM Module .. 1-29

A

access stop switch 2-27
 ACT LED 2-23
 adjacent two-gauge method 2-13
 alarm 1-9
 alarm output timing 1-9
 alarm value hysteresis 1-9
 API for the MX100/DARWIN 1-1
 attaching the modules 2-3
 attachment procedure 2-4

B

backup mode 1-10
 base plate 1-5

C

calibration 3-6
 calibration of temperature measurements 3-11
 calibration procedure 3-6
 calibration software 1-6
 Calibrator 1-6
 CF card 1-11, 2-27
 CF card data file 5-9
 CF card specifications 1-13
 channel number 2-5
 chattering 1-26
 checking the CF card status 1-12
 checking the communication status 2-23
 commercial power noise 2-24
 common mode voltage 1-15, 1-17, 1-19, 1-21, 1-22
 communication commands 3-13
 communication errors 3-2
 communications 1-7
 communication status 2-23
 computation 1-8
 connecting the signal wires 2-6
 contact input 2-16
 current 2-17
 cutoff frequency 2-26

D

data viewer software 1-6
 DC voltage/current standard 3-6, 3-11
 de-energize 1-35
 difference computation between channels 1-8
 Differential lower limit alarm 1-9
 Differential upper limit alarm 1-9
 DIN rail 2-3
 DIN rail mount bracket 2-3
 dip switch 1-7, 2-23, 5-1
 display of the self-test operation at power on 1-10
 display when operation is complete 1-10
 dual save 5-3
 dual save function 5-1

E

eject lever 2-27
 energize 1-35
 error display 3-1
 errors at power ON 3-1
 ethernet 2-22
 ethernet port 2-22
 expendable parts 3-12
 explanation of functions 5-2
 external power supply 2-17

F

file name 5-9
 file structure and saved channels 1-11
 filter 1-8, 1-15, 1-17, 1-19, 1-21, 1-22, 1-26
 first-order lag filter 1-8, 2-26
 four-gauge method 2-15

H

hold 1-35

I

idle mode 1-10
 initial balancing 1-23
 initializing the settings 2-23
 initial unbalance value adjustment 1-23
 input/output modules 1-2
 input type 1-14, 1-16, 1-18, 1-20
 installation 2-2
 installation location 2-2
 installation procedure 2-2
 integrating A/D converter 2-24
 Integration Monitor 1-6
 integration time 1-15, 1-17, 1-19, 1-21, 1-22

L

linear scaling converts 1-8
 LINK LED 2-23
 log file example 1-13
 low-pass filter 2-26
 lower limit alarm 1-9
 lower limit on rate-of-change alarm 1-9

Index

M

main module	1-2, 1-7
maintenance/test	3-13
maintenance/test commands.....	3-13
maintenance of parts	3-12
MATH.....	1-8
measurement.....	1-7
measurement and saving of data to CF card	5-6
measurement interval.....	1-15, 1-17, 1-19, 1-21, 1-22, 1-26
measurement mode.....	1-10
measurement range	1-14, 1-16, 1-18, 1-20, 1-22
measurement synchronization.....	1-15, 1-17, 1-19, 1-21, 1-22
measurement time.....	1-8
measures against noise.....	2-24
media-related errors	3-2
metal for discharging the static electricity.....	2-27
module errors	3-2
MX100 Operation and Status Relative to CF Card	
Operation	1-12
MX100 Standard Software	1-1, 1-6
MXLOGGER.....	1-1

N

noise rejection filter.....	1-15, 1-21
non-hold.....	1-35

O

one-gauge method	2-12
one-gauge three-wire method	2-13
one-to-N connection	1-1
one-to-one connection	1-1
operation mode display	1-10
operation of the CF card.....	1-12
operation when errors occur upon startup.....	1-28
opposing two-gauge method	2-14
opposing two-gauge three-wire method	2-14
output command help.....	3-15
output connection information	3-14
output ethernet statistical information.....	3-14
output on disabled channels.....	1-29
output operation during calibration	1-27
output operation per settings and setting changes.....	1-29
output other network information	3-15
output range	1-27, 1-28
output relay.....	1-35
output selection when errors occur upon startup.....	1-29
output status	1-29
output type.....	1-27, 1-28, 1-35
output update interval.....	1-27, 1-28, 1-35
output waveform.....	1-28
output when abnormal, or after recovery from abnormality	1-32
overview	1-1
overview of functions	5-1

P

panel mount.....	2-2
PC software	1-6
plates with clamped terminals	2-8
plates with screw terminals.....	2-8
power connection	2-19
power supply terminal.....	2-20
power switch.....	2-21
pulse interval	1-28
pulse width output.....	2-17

Q

quit maintenance/test	3-16
-----------------------------	------

R

rack mount.....	2-2
reference junction compensation.....	3-11
relay action and hold behavior.....	1-35
remote RJC	1-8
RRJC.....	1-8
RTD	2-11

S

saving data	1-11
saving data to the CF card	5-3
screw terminal block	2-8
shunt resistor	2-11
slot cover	2-27
specifications	
10-CH, High-Speed Digital Input Module.....	4-26
10-CH, Medium-Speed Digital Output Module.....	4-33
10-CH, Medium-Speed Universal Input Module.....	4-12
30-CH, Medium-Speed DCV/TC/DI Input Module.....	4-16
4-CH, High-Speed Universal Input Module.....	4-8
4-CH, Medium-Speed Strain Input Module	4-24
6-CH, Medium-Speed Four-Wire RTD Resistance	
Input Module.....	4-20
8-CH, Medium-Speed Analog Output Module.....	4-27
8-CH, Medium-Speed PWM Output Module	4-29
base plate.....	4-7
common specifications.....	4-1
main module.....	4-2
mechanical.....	4-1
operations common to the Analog output module and	
standard operating conditions	4-1
steady output operation	1-31
supported standards.....	4-1
synchronization.....	1-7
synchronization between channels.....	1-7
synchronization between modules	1-7
system errors.....	3-1

T

terminal arrangement markings.....	2-6
terminal block	2-7
terminal cover.....	2-6
terminal emulator.....	3-13
thermocouple.....	2-11
time constant	1-8, 2-26
time information	1-8
transistor input	2-16
transmission output	1-27, 1-28, 1-29
transport and storage conditions	4-1
troubleshooting	3-3

U

unit number.....	1-10
upper limit alarm	1-9
upper limit on rate-of-change alarm.....	1-9
user output.....	1-27, 1-28, 1-29

V

Viewer.....	1-6
voltage	2-17

W

wiring	
Analog Output Modules.....	2-17
Digital Input Modules.....	2-16
Digital Output Modules.....	2-18
Four-Wire RTD Resistance Input Modules	2-12
PWM Output Modules	2-17
Strain Input Modules	2-12
Universal/DCV/TC/DI Input Modules.....	2-11
wiring procedure	2-11